



Making cooking as much fun as eating

Please read this instruction manual. This will ensure that you make use of all the technical benefits the cooker has to offer. You will be given important safety information. You will then be introduced to the individual components of your new cooker and we will show you how to adjust it step by step. It is quite simple.

The tables list the settings and shelf heights for numerous well-known dishes. All these dishes are tested in our cooking studio.

In the unlikely event of a fault, look here for information on how to rectify minor faults yourself.

A detailed table of contents will help you to find your way around quickly.

Enjoy your meal!

Instruction manual

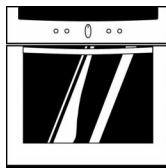

B 4542.0

en

9000 264 054

Table of contents

Important information	5
Before installation	5
Safety information	5
Reasons for damage	7
Your new cooker	8
The control panel	8
Function selectors	8
Temperature selector	9
Control buttons and display panel	10
Push-in control knobs	10
Types of heating	10
Oven and accessories	13
Cooling fan	15
Before using for the first time	16
Heating up the oven	16
Pre-cleaning the accessories	16
Setting the oven	17
Switching off the oven manually	18
Switching the oven off automatically	19
Switching the oven on and off automatically	20
Residual heat indicator	21
Rapid heating	21
Setting procedure	21

Table of contents

Steam cooking setting	22
Setting procedure	22
Proving setting	23
Setting procedure	23
Time	25
Setting procedure	25
Timer	26
Setting procedure	26
Child-proof lock	27
Locking the oven for a short time	27
Locking the oven permanently	27
Automatic time limiter	28
Pyrolysis	28
Setting procedure	29
You want self-cleaning to switch on and off automatically	30
When the oven has cooled down	31
Care and cleaning	31
Oven exterior	31
Oven	32
Cleaning the glass panels	34
Cleaning the rails	36
Seal	36
Accessories	36

Table of contents

Troubleshooting	37
Replacing the oven light	37
After-sales service	38
Packaging and old appliances	39
Tables and tips	39
Baking	40
Baking table	41
Baking with the Pizza setting	43
Baking tips	44
Meat, poultry, fish	45
Roasting	45
Grilling	46
Roasting table	47
Grilling table	48
Tips for roasting and grilling	49
Defrosting and cooking using hot air	50
Preserving	51
Energy saving tips	53
Acrylamide in foodstuffs	54
Test dishes	55

Important information

Read this instruction manual carefully. Only then will you be able to operate your cooker safely and correctly.

Please keep the instruction and installation manual in a safe place. Please pass on the instruction manual to the new owner if you sell the appliance.

Before installation

Transport damage

Check the appliance after unpacking it. Do not connect the appliance if it has been damaged in transport.

Electrical connection

The cooker may only be connected by an approved specialist. Losses resulting from damage caused by incorrect connection will invalidate warranty claims.

Safety information

This appliance is intended for domestic use only. Only use the cooker for food preparation.

Adults and children must not operate the appliance without supervision

- if they are physically or mentally incapable of doing so
- or if they lack the knowledge and experience required to operate the appliance correctly and safely.

Never let children play with the appliance.

Children



Children may prepare meals only if they have been properly instructed. They must be able to operate the appliance correctly. They must understand the hazards indicated in the instruction manual. When children use the appliance, they must be supervised to prevent them from playing with it.

Hot oven



Open the oven door carefully. Hot steam may escape. Never touch the internal surfaces of the oven or the heating elements. There is a risk of burning. Children must be kept at a safe distance from the appliance.

Never store combustible items in the oven. Risk of fire

Never clamp leads of electrical appliances in the hot oven door. The insulation on the leads could melt. There is a risk of short-circuiting.

Repairs



Incorrectly done repairs are dangerous. There is a risk of electrocution.

Repairs may only be carried out by after-sales service technicians who have been fully trained by BSH.

If there is a fault, switch off the oven fuse at the fuse box.

Call the after-sales service.

Automatic self-cleaning



Loose food residue, grease and meat juices may ignite during self-cleaning. Risk of fire. Before every self-cleaning operation, remove any coarse dirt from the oven.

Never hang flammable items, such as tea towels, on the door handle. Risk of fire.

The oven exterior will be very hot to the touch during the self-cleaning operation. Keep children at a safe distance.

Never clean metal sheets and dishes which have been coated with a non-stick coating using the oven's automatic self-cleaning function (pyrolysis operation). High temperatures can cause poisonous gases to be formed from the non-stick coating - risk of serious damage to health.

Reasons for damage

Baking tray, aluminium foil or dishes on the oven floor

Do not place the baking tray on the oven floor. Do not cover it with aluminium foil.

Do not place dishes on the oven floor.

This will cause heat accumulation. The baking and roasting times will no longer be correct and the enamel will be damaged.

Water in the oven

Never pour water directly into a hot oven. This could damage the enamel.

Fruit juice

When baking very moist fruit cakes, do not put too much on the baking sheet. Fruit juice dripping from the baking sheet leaves stains that cannot be removed.

It is recommended that you use the deeper universal pan.

Cooling with the oven door open

Only leave the oven to cool with the door closed. Do not allow anything to become trapped in the oven door. Even if you only leave the oven door open slightly, the fronts of adjacent units may become damaged over time.

Very dirty oven seal

If the oven seal is very dirty, the oven door will no longer close properly when the oven is in use. The fronts of adjacent units could be damaged. Keep the oven seal clean.

Using the oven door as a seat

Do not stand or sit on the oven door.

Transporting the cooker

Do not hold or carry the cooker by the door handle. The door handle cannot hold the weight of the cooker and may break off.

Your new cooker

Here you will learn more about your new oven. The control panel and its switches and indicators are explained here. The heating modes and the accessories included with your oven will be explained here.

The control panel

Details vary according to the appliance model.

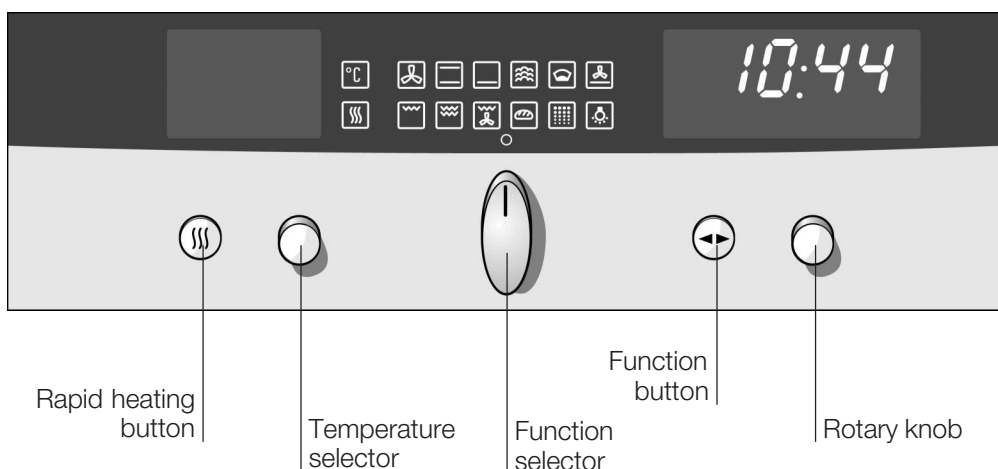





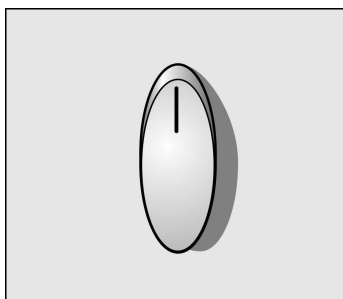

Function selectors





Use the function selector to select the type of heating for the oven. The default value for each type of heating appears in the display.



Settings

	CircoTherm hot air
	Top/bottom heating
	Bottom heating
	Steam setting
	Dough proving setting
	Pizza setting
	Centre-area grill

Settings

	Full-surf. area grill
	Thermo grilling
	Bread baking setting
	Pyrolysis
	Oven light

The light comes on in the oven when you set the function selector.

Temperature selector

A default value appears if you have selected a type of heating using the function selector. Set the temperature or cleaning level required using the temperature selector.

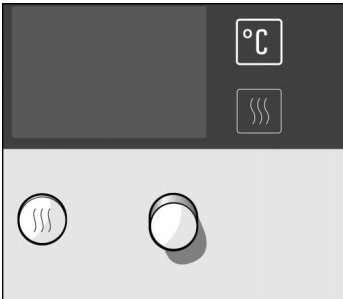

Temperature

40-275	Temperature in °C
---	Defrosting with CircoTherm hot air

Cleaning



1	Light cleaning
2	Moderate cleaning
3	Intensive cleaning

The  symbol lights up when the oven is heating up. It goes out during pauses in heating.

Rapid heating button

This allows you to heat up the oven particularly quickly.

Notes

The steam cooking setting  and the dough proving setting  types of heating have a fixed temperature setting that cannot be changed.

Control buttons and display panel



Function button ◀ ▶ This is used to select the clock ☹, the timer 🔔, the cooking time |→| and the end time →|.

Rotary knob This is used to set the clock, timer, cooking time or end time.

The values set can be seen in the display panel.

Push-in control knobs

The function selector, the temperature selector and the rotary knob can be pushed in. Press the control knob or the knob briefly to release it or push it in.

Types of heating

Different types of oven heating are available. You can therefore select the best method for cooking any dish.

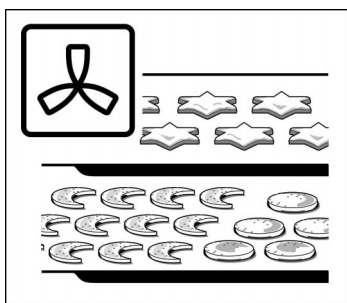

CircoTherm hot air

A fan in the rear wall distributes the heat from the ring heating element evenly inside the oven. This means that the heat is transferred particularly effectively to the items you are baking or roasting.

Using CircoTherm hot air, it is possible to bake cakes and pizza on two levels. You can cook biscuits and puff pastry on three levels at the same time. Additional baking trays may be obtained from specialist shops.

The required oven temperatures are lower than those for Top/bottom heating.

CircoTherm hot air is ideally suited to preserving and defrosting.

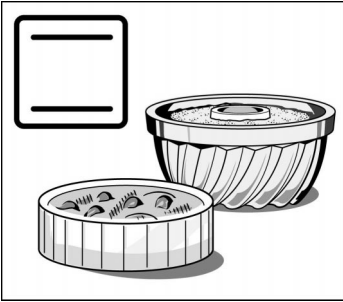

Top/bottom heating

This ensures even distribution of heat onto the cake or roast from the top and bottom of the oven.

This type of heating is best for sponge cakes in tins or for bakes. Top and bottom heating is also suitable for cooking lean joints of beef, veal and game.

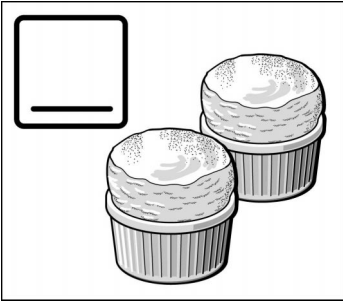

Bottom heating

Only the bottom heating element in the oven heats up. You can use Bottom heating for the final baking of dishes that require particular browning on the underside. To achieve this, use Bottom heating at the end of the baking or roasting time.

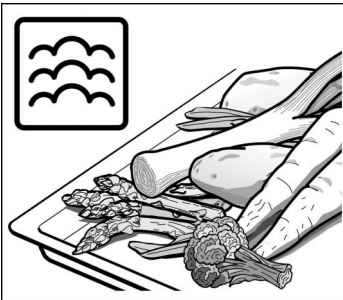

Steam setting

Bottom heating is used for the Steam setting. This type of heating is used in conjunction with the System steamer. You can obtain this as an accessory from your local specialist retailer.

The Steam setting is particularly suitable for cooking vegetables and fish, whilst still retaining all the nutrients and flavour.

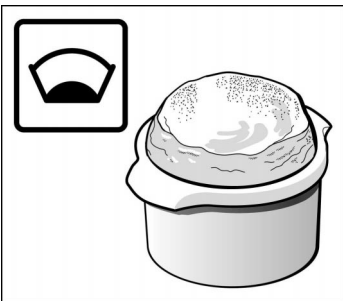

Dough proving setting

The proving setting is ideal for letting yeast dough rise. The dough rises quickly and evenly. It does not dry out and is protected from unfavourable external influences (e.g. draughts).

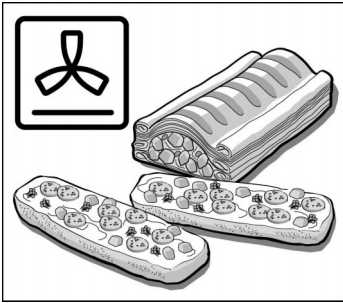

Pizza setting

For this, Bottom heating is switched on in addition to CircoTherm hot air.

This type of heating is particularly suitable for fresh, juicy meals and for frozen foods. It is ideal for sweet strudel or frozen pizza and chips.

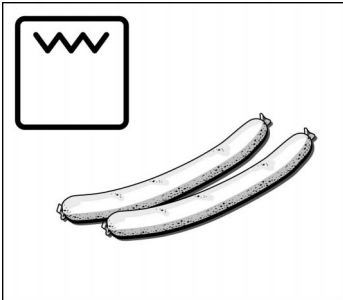

Centre-area grill

Only the middle section of the grill heating element is switched on.

This type of heating is ideal for cooking small quantities. This saves energy. Place the pieces to be grilled in the centre of the wire rack.

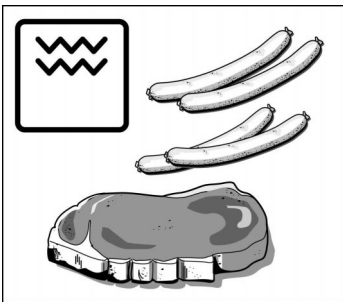

Full-surf. area grill

The entire area under the grill element becomes hot. This is ideal if you wish to grill several steaks, sausages, pieces of fish or slices of bread.

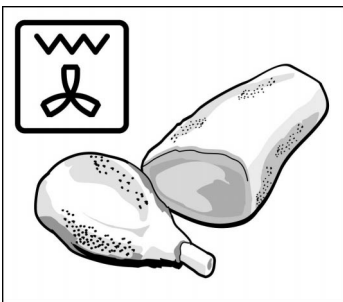

Thermo grilling

This type of heating involves the grill element and the fan switching on and off alternately. During the pause in heating, the fan circulates the heat generated by the grill around the food. This ensures that pieces of meat are crisped and brown on all sides.

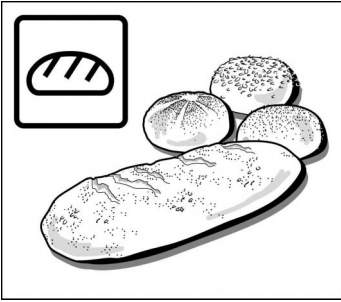

Bread baking setting

With the bread baking setting, the heat in the oven is regulated to the optimum with CircoTherm hot air. The inside of the bread does not dry out and the crust becomes crisp.

Oven and accessories

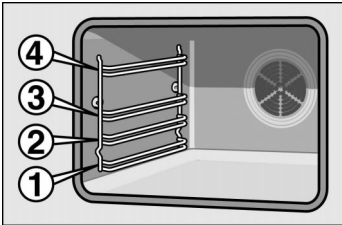

The accessories can be inserted into the oven at 4 different heights.

The shelf heights are counted from bottom to top and are marked on the oven.

You can remove the shelf two thirds of the way without it tipping. This allows the meals to be removed easily.

Do not use shelf height 2 for types of heating with **CircoTherm hot air**. The air circulation would otherwise be impaired.

Accessories

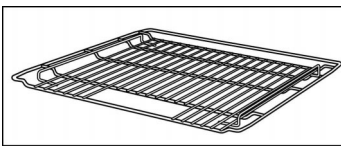

Cranked wire rack

For ovenware, cake tins, roasts, grilling and frozen meals.

Insert the wire rack curving downwards .

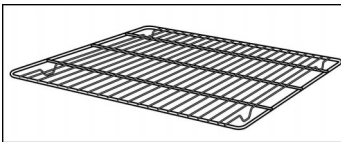

Close-meshed wire rack

For ovenware, roasts, grilling and frozen meals.

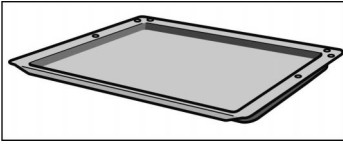

Enamelled baking tray

for cakes and biscuits.

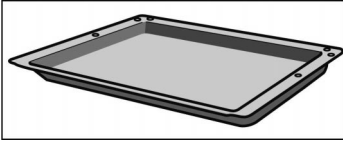

Universal pan

for moist cakes, pastries, frozen food and large roasts. It can also be used to catch dripping fat when you are grilling directly on the wire grill.

Accessories may be purchased from the after-sales service or from specialist shops.

The availability of accessories varies from country to country. Please consult our sales brochures.

Accessories	Order no.
Mega System steamer	N 8642X0
System steamer	N 8642X0 EU
Universal pan, enamelled	Z 1232X0
Universal pan with non-adhesive coating	Z 1233X0
Universal pan with insert grid	Z 1242X0
Glass pan	Z 1262X0
Gratin dish, enamelled	Z 1272X0
Baking tray, enamelled	Z 1342X0
Baking tray with non-adhesive coating	Z 1343X0
Pizza tin	Z 1352X0
Cranked wire rack	Z 1432X0
Close-meshed wire rack	Z 1442X0
Roasting sheet, enamelled	Z 1512X0
CLOU 3-fold telescopic shelf	Z 1742X1
CLOU 4-fold telescopic shelf	Z 1752X1
Bread-baking stone	Z 1912X0
Universal roasting dish, enamelled	Z 9930X0

Note

The baking tray or universal pan may distort while the oven is operating. This is caused by significant differences in temperature on the accessories. It may happen when the tray/pan is only part-full or when frozen items have been placed on them, e.g. pizza. This distortion will disappear as baking, roasting or grilling proceeds.

Cooling fan

The oven is fitted with a cooling fan. It switches itself on and off as necessary. The warm air escapes above the door.

Before using for the first time

This section tells you everything you need to do before using the cooker for the first time.

Heat the oven and clean the accessories. Read the safety instructions in the “Important information” section.

Firstly, check to see if the three zeros are flashing in the display.

If three zeros are flashing in the display

Set the time.

1. Press and hold the ◀▶ button until the ☹ symbol begins to flash.
12:00 appears in the display.
2. Set the time using the rotary knob when the ☹ symbol is flashing.

The time is adopted after a few seconds. The cooker is now ready for use.

Heating up the oven

Method

Heat the empty oven with the door closed to remove the new oven smell.

1. Set the function selector to Top/bottom heating .
170 °C appears in the display as a default value.
2. Set the temperature to 240 °C using the temperature selector.

Switch off the function selector after 60 minutes.

Pre-cleaning the accessories

Please wash the accessories thoroughly with soapy water and a cleaning cloth before using them.

Setting the oven

Switching off the oven manually

There are various ways in which you can set your oven.

The oven switches off automatically

The oven switches off automatically when the meal is ready.

The oven switches on and off automatically











You can leave the kitchen for a long time.

You can set the oven so that you place the meal in the oven in the morning and it is ready at lunch time.

Tables and tips

In the “Tables and tips” section, you will find suitable settings for many dishes.

Heating types and temperature ranges

Type of heating	Default temperature	Temperature range
 CircoTherm hot air Defrost	160 ---	40-200 Fixed temp.
 Top/bottom heating	170	50-275
 Bottom heating	200	50-225
 Steam cooking setting		Fixed temp.
 Dough proving setting	-0-	Fixed temp.
 Pizza setting	220	50-275
 Centre-area grill	180	50-275
 Full-surf. area grill	220	50-275
 Thermo grilling	170	50-250
 Bread baking setting	200	180-220

Switching off the oven manually

Example: Top/bottom heating , 190 °C

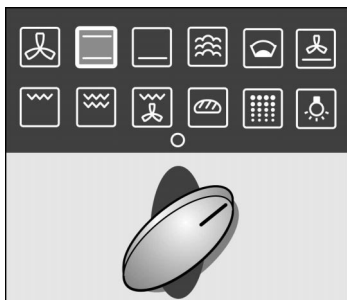

1. Select the desired type of heating using the function selector.

The default value for this type of heating appears in the temperature display.

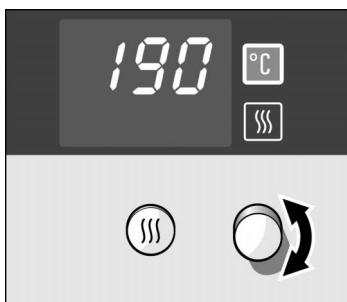

2. Use the temperature selector to set the temperature.

Switching off

Switch off the function selector when the meal is ready.

Changing the setting

You may change the temperature or grill setting at any time.

Note

While the oven is heating up, you can call up the current heating temperature using ◀▶ button.

Switching the oven off automatically

Example: for a cooking time of 45 minutes

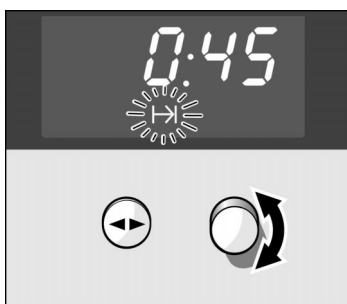

Make the settings as described in steps 1 and 2. Set the cooking time (duration) for your meal. You can set a maximum of 6 hours.

3. Press the ◀ ▶ button until the I→I cooking time signal begins to flash.

4. Use the rotary knob to set the cooking time.

The oven switches on after a few seconds. The time reappears in the display. The I→I symbol lights up.

The duration has elapsed

A signal sounds. The oven switches off. The I→I cooking time symbol flashes. You can clear the signal by pressing the ◀ ▶ button in good time. Switch off the function selector.

Changing the setting

Press the ◀ ▶ button until the I→I cooking time signal begins to flash. Use the rotary knob to change the cooking time.

Cancelling the setting

Press the ◀ ▶ button until the I→I cooking time signal begins to flash. Turn the cooking time back to 0:00 using the rotary knob. Switch off the function selector.

Calling up settings

Press the ◀ ▶ button until the corresponding symbol begins to flash. The value called up will then appear for a few seconds.

Switching the oven on and off automatically

Example: the time is 10:45 a.m. The meal will take 45 minutes to cook and must be ready at 12:45 pm

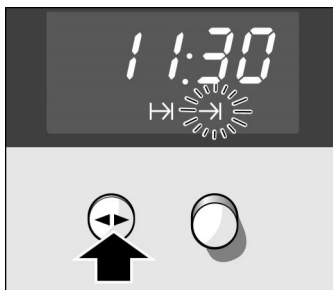

Please remember that easily spoiled foods must not be allowed to remain in the oven for too long.

Set the oven settings as described in steps 1 to 4.

5. Press the ◀ ▶ button until the →| symbol begins to flash.
In the display you will see the time when the meal will be ready.

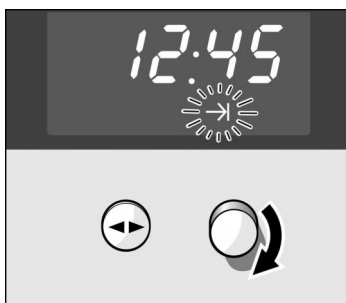

6. Use the rotary knob to set a later end time.

The setting is adopted after a few seconds. The time reappears in the display. The →| end symbol lights up until the oven starts. The |→ cooking time symbol then lights up.

The duration has elapsed

A signal sounds. The oven switches off. The →| end time symbol flashes.

Press the ◀ ▶ button. The →| end symbol goes out. Switch off the function selector.

Cancelling the setting

Press the ◀ ▶ button until the |→ cooking time signal begins to flash. Turn the cooking time back to 0:00 using the rotary knob. Switch off the function selector.

Note

You can change the setting while the symbol is flashing. The setting has been adopted if the symbol lights up permanently.

Residual heat indicator

When you switch off the oven, the residual heat in the oven is indicated in the temperature display. The *H* symbol remains lit until the temperature has dropped to approximately 120 °C. It then changes to *h* and goes out when the temperature is below 80 °C.

Using residual heat

You can keep food warm in the oven using residual heat.

For dishes with a long cooking time, you can switch off the oven 5-10 minutes earlier. The dish will finish cooking using residual heat. This saves energy.

Rapid heating



This allows you to heat up the oven particularly quickly.

Suitable type of heating

 CircoTherm hot air

Setting procedure

First set the oven.

Then press the  rapid heat up button. The  symbol lights up in the display. The oven will heat up.

Rapid heat up is complete

The  symbol goes out. Put your dish in the oven.

Note

While the oven is heating up, you can call up the current heating temperature using ◀▶ button.

Steam cooking setting

The steam cooking setting is particularly suitable for cooking vegetables and fish, whilst still retaining all the nutrients and flavour. Only use the steam cooking setting with the System steamer. You can obtain this as an accessory from your local specialist retailer.

Setting procedure

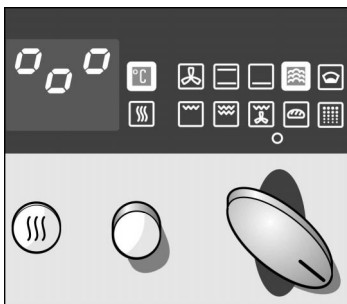

$\square\circ\square$ and H or h flash alternately in the display

Switching off

Note

The oven must be completely cooled down.

Set the function selector to .

The  symbol lights up. $\square\circ\square$ appears in the temperature display.

The steam cooking setting adjusts automatically.

The oven is still too hot. Switch off the function selector and wait until the oven has cooled down to room temperature.

Make the settings again.

Switch off the function selector.

You will find further information in the instruction manual for the System steamer.



Any other uses or operating modes are not permitted.

Proving setting

The proving setting is ideal for letting yeast dough rise.

Setting procedure

The oven must have fully cooled down.
Never pour cold water into a hot oven.
Only use ordinary tap water; do not use distilled water.
Do not pour water into the oven when making yoghurt.

1. Carefully pour 50 ml of water into the base tray of the cold oven.
2. Slide the wire rack into level 1.
Place the bowl containing the dough in the middle of the wire rack. Do not cover the dough.
3. Close the oven door.
4. Set the function selector to proving setting .
The  symbol lights up.  appears in the temperature display.

The proving process is controlled automatically.

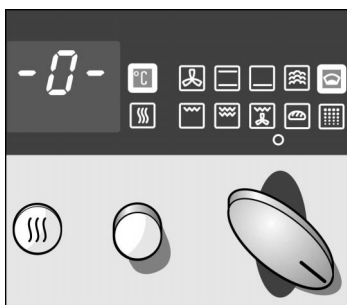

 and *H* or *h* flash alternately in the display

The oven is still too hot. Switch off the function selector and wait until the oven has cooled down to room temperature.
Make the settings again.

Switching off

Switch off the function selector.

Table

The values in the table are average values. They may vary depending on the type and quantity of dough and the composition of the ingredients.

Yeast dough	Quantity of flour	Proving time in minutes
Cook until	500 g	20-25
Cook until	500-750 g	25-30
Dough for a plaited loaf	500 g	30-35
Dough for a plaited loaf	750 g	30-40
Bread dough	1000 g	35-60
Yoghurt	1 litre milk	6 hours

Note

You will find recipes in the accompanying cookbook.

Before baking, remove any remaining water from the oven. Any water marks should be removed using a little vinegar and wiped away with clean water.

Time

When the oven is first connected or following a power cut, three zeros will flash in the display. Set the time.

Setting procedure

Example: 13:00

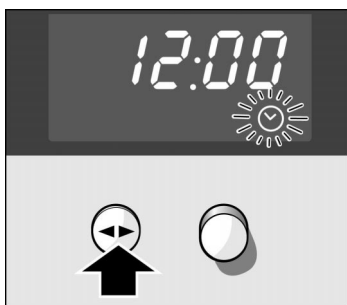

1. Press the ◀▶ button until the ⌚ symbol begins to flash in the display.



2. Use the rotary knob to set the time while the ⌚ symbol is flashing.

The time selected is adopted after a few seconds. The ⌚ symbol will go out.

Changing the time, e.g. from summer to winter time

Press the ◀▶ button until the ⌚ symbol begins to flash. Use the rotary knob to change the time.

Hiding the time

You can hide the time.
Press and hold the ◀▶ button for seven seconds until the display goes out.
Briefly press the ◀▶ button to show the display again.

Timer

You can use the timer as a kitchen timer. It operates independently of the oven. The timer has a special signal. This enables you to hear whether the timer or an oven cooking time has elapsed.

You can also set the timer when the child-proof lock is active. You can set a maximum of 23:59 hours.

Setting procedure

Example: 20 minutes

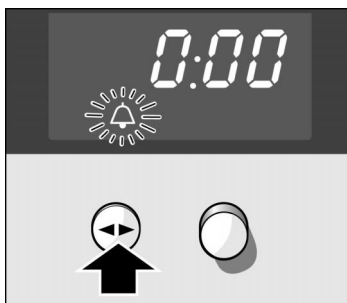

1. Press the ◀▶ button until the 🔔 timer symbol begins to flash in the display.



2. Set the timer using the rotary knob.

The timer starts after a few seconds. The 🔔 symbol lights up in the display. The time counts down in the display.

The time has elapsed

A signal sounds. Press the ◀▶ button. The timer display will go out.

Changing the timer period

Press the ◀▶ button. Change the time using the rotary knob.

Cancelling the setting

Press the ◀▶ button. Change the time to 0:00 using the rotary knob until the display shows zero.

Child-proof lock

The oven has a child-proof lock to prevent children switching it on accidentally.

Locking the oven for a short time

Locking the oven

Turn the function selector anti-clockwise from position 0 to  and back again three times in quick succession.

–5– appears in the display.

Unlocking

Turn the function selector anti-clockwise from position 0 to  and back again three times in quick succession.

–5– goes out.

Note

You can still set the time and the timer when the oven is locked.

Locking the oven permanently

The oven is always locked 30 seconds after the function selector is switched off.

Locking the oven

Turn the function selector anti-clockwise from position 0 to  and back again six times in quick succession.

–5P appears in the display.

Setting the oven

Turn the function selector anti-clockwise from position 0 to  and back again three times. Now you can set the oven.

Cancelling the permanent lock

Turn the function selector anti-clockwise from position 0 to  and back again six times in quick succession.

–5P goes out.

Automatic time limiter

If you have forgotten to switch off the oven, the automatic time limiter will be activated. Oven operation will be interrupted. The temperature set determines when this will happen.

If the oven is no longer heating up, **000** flashes in the display.

Heating is interrupted until the function selector is switched off. **000** goes out.
Now you can reset the oven.

Pyrolysis

The oven is heated to approximately 500 °C. Any food residues from roasting, grilling and baking are burnt to ash.

You may choose from three cleaning levels.

Level	Degree of cleaning	Duration
1	light	approx. 1 hour 15 minutes
2	moderate	approx. 1 hour 30 minutes
3	intensive	approximately 2 hours

What you should know

For safety reasons, the oven locks automatically when it reaches approximately 300 °C. You will only be able to open the oven door again once the temperature has fallen below 300 °C.



The exterior of the oven will become very hot. Make sure that nothing is placed against the front panel. Keep children at a safe distance.

Never attempt to open the oven door during pyrolysis. The cleaning process may be interrupted.

Please do not attempt to push in the latch by hand.

The oven light does not light up during cleaning.

Before pyrolysis

The oven must be empty. Take any accessories, ovenware and shelves out of the oven.
For information about removing the shelves, see the Care and cleaning section.

If you forget to take the shelves out of the oven, a signal sounds. Automatic self-cleaning does not start.



Risk of fire. Loose food residue, grease and meat juices are flammable.

Wipe the oven and the accessories that are to be cleaned at the same time with a damp cloth.

Clean the oven door and along the edges of the oven around the seal. Do not scour the seal.

Make sure that the oven door is closed before you start cleaning.

Setting procedure

Example: cleaning level 3

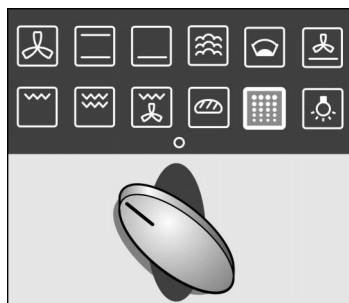

1. Set the function selector to .
A zero appears in the display.



2. Use the temperature selector to set level 3.

Automatic self-cleaning starts after several seconds.
The  symbol lights up in the display.

The cleaning time has elapsed

Calling up the duration and end time

You want self-cleaning to switch on and off automatically

Example: You want automatic self-cleaning to finish at 23:00.

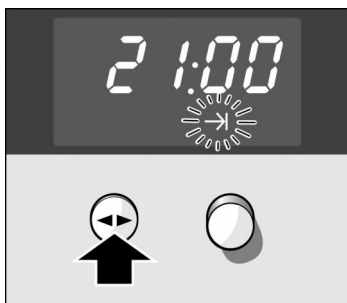

The cleaning time has elapsed

Cancelling the setting

Note

The I→I duration symbol goes out. Do not switch off the function selector until the oven door can be opened.

To call up the remaining duration I→I or end time →I: Press the ◀▶ button repeatedly until the corresponding symbol appears.

You can also set the oven so that cleaning runs at night, for example. Then the oven will be available at all times during the day.

Set the oven as described in steps 1 and 2.

3. Press the ◀▶ button repeatedly until the →I end symbol flashes.
The display shows when automatic self-cleaning will be finished.

4. Extend the end time using the rotary knob.

The self-cleaning function switches on and off at the appropriate times.
The time reappears once self-cleaning has started.

The I→I duration symbol goes out.
Do not switch off the function selector until the oven door can be opened.

Switch off the function selector.

The cleaning level can no longer be changed once the cleaning operation has been started.

When the oven has cooled down

Wipe away any remaining ash from inside the oven using a damp cloth.

Hook the shelves back in place. To do this, please refer to the care and cleaning section.

Note

Under normal use, it is usually sufficient to clean the oven every two to three months. Cleaning only requires approximately 2.5 to 4.7 kilowatt-hours.

The special heat-resistant enamel and the shiny parts in the oven may become dull or discoloured after time. This is normal and does not affect their function. Do not use coarse scouring pads or strong cleaning agents to remove such discolouration.

Care and cleaning

Do not use high-pressure cleaners or steam jets.

Oven exterior

Wipe the oven with water and a little washing-up liquid. Dry it with a soft cloth.

Caustic or abrasive substances are not suitable. If any such substances come into contact with the frontage, wipe it off immediately with water.

Note

Slight differences in the colours on the appliance front are caused by the use of different materials, such as glass, plastic and metal.

Shadows on the door panel which resemble smears are reflections from the oven light.

Appliances with stainless steel fronts

Always remove any flecks of limescale, grease, cornflour and egg white immediately. Corrosion can form under such flecks.

Appliances with aluminium fronts

Use stainless steel care products. Follow the manufacturer's instructions. Try out the product on a small area first, before using on the whole surface.

Use a mild window-cleaning detergent. Wipe the area with a soft window cloth or a fluff-free micro-fibre cloth, using a horizontal action without applying pressure.

Aggressive cleaning products, scratchy sponges and rough cleaning cloths are not suitable.

Oven

Never use coarse scouring pads or cleaning sponges. Oven cleaner may only be used on enamelled oven surfaces.

For ease of cleaning

you can switch on the oven light and detach the oven door.

Switching on the oven light

Set the function selector to .

Detaching the oven door



Make sure that you do not reach into the hinge. There is a risk of injury.

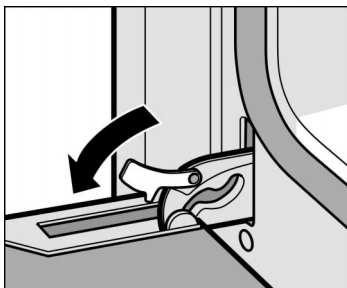

1. Open the oven door fully.
2. Move the two locking levers on the left and right-hand sides.

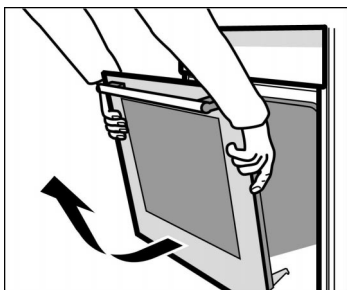

3. Half-close the oven door.
With both hands, grip the door on the left and right-hand sides.
Close the door a little more and pull it out.

After cleaning, refit the oven door in the reverse order to removal.

Cleaning the enamelled surfaces of the oven

Use hot soapy water or a vinegar solution.

It is best to use oven cleaner if the oven is very dirty. Only use oven cleaner in a cold oven.

Note:

Enamel is baked on at very high temperatures. This can cause some slight colour variation. This is normal and does not affect the function. Do not use coarse scouring pads or strong cleaning agents to remove such discolorations.

The edges of thin trays cannot be completely enamelled. As a result, these edges can be rough. Anti-corrosion protection is guaranteed.

Cleaning the glass cover for the oven light

It is best to clean the glass cover with washing-up liquid.

Cleaning the oven door cover

The oven door cover can become discoloured. You must remove the cover in order to clean it.

Proceed as follows:

1. Open the oven door fully.
2. Unscrew the cover at the top of the oven door. To do this, undo the right and left-hand screws.
3. Remove the cover–

Make sure that the oven door is not closed while the cover is removed. The inner glass may be damaged.

Clean the cover with a stainless steel cleaning agent.

4. Replace the cover and fasten it.
5. Close the oven door.

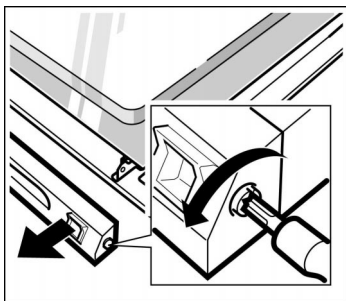

Cleaning the glass panels

Removal

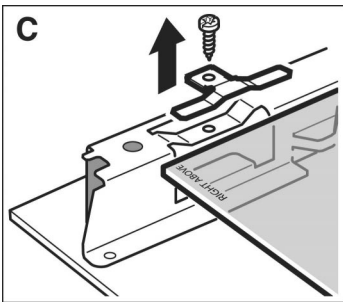
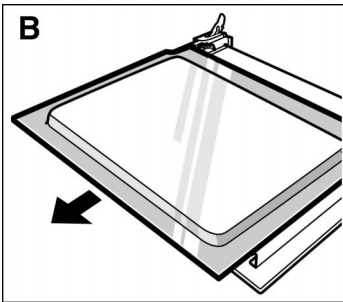
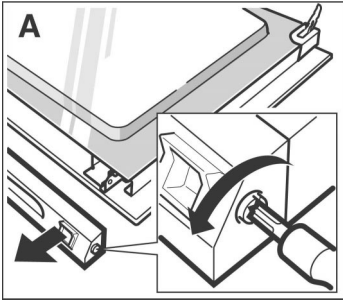

The glass panel on the oven door can be removed to assist in cleaning.

1. Remove the oven door and lay it down on a cloth with the handle facing downwards.
2. Unscrew the cover at the top of the oven door. Turn the screws clockwise or anti-clockwise to do this. (Fig. A)
3. Raise the upper panel and remove it. (Fig. B)
4. Unscrew the clips on the left and right and remove them. (Fig. C) Remove the panel.
5. The seal at the bottom of the panel can be removed for cleaning. To do this, unhook the seal on the left and right.

Clean the glass panels with glass cleaner and a soft cloth.

Do not use sharp or abrasive materials or a glass scraper. The glass could be damaged.

Installation

Ensure that the label “right above” is upside down at the bottom left of both panels.

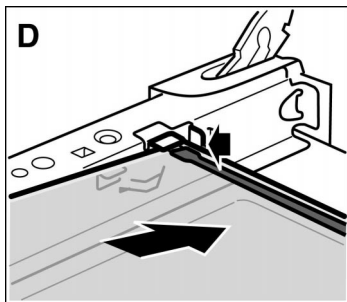

1. Slide in the glass panel backwards at an angle. (Fig. D)
2. Replace the seal again at the bottom of the panel. (Fig. D)

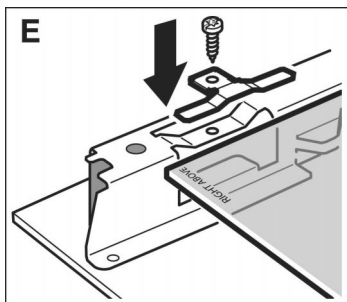

3. Fit the clips and screw them in again. (Fig. E)
4. Slide in the top panel backwards at an angle.
5. Replace the cover and screw it back on.
6. Refit the oven door.

The oven must not be used again until the panels have been correctly installed.

Cleaning the rails

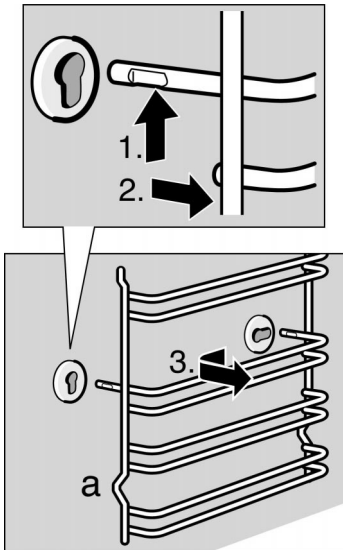

The rails can be removed for cleaning.

To unhook the rails:

1. Lift the rail at the front in an upwards direction
2. and unhook it.
3. Then pull the whole rail forward and take it out.

Clean the rails using either washing-up liquid and a sponge or a brush.

To hook rails back into position:

First insert the rail in the rear socket, push it back slightly and then hook it into the front socket.

The rails fit both the left and right sides. Recess (a) must always be at the bottom.

Seal



Clean the seal on the oven with washing-up liquid. Never use caustic or abrasive detergents.

Accessories

Immediately after use, soak the accessories in washing-up liquid. Food residues can then be easily removed with a brush or sponge.

Troubleshooting

Malfunctions often have simple explanations. Please read the following instructions before calling the after-sales service:

Problem	Possible cause	Comments/remedy
The appliance does not work.	Blown fuse	Look in the fuse box and check that the fuse is in working order.
The clock display flashes.	Power cut	Reset the clock.
The oven door cannot be opened. The function selector is in the  pyrolysis position and three zeros flash in the display	Power cut	Switch off the function selector. Reset the clock and start pyrolysis again. If you do not wish to repeat pyrolysis, wait until the oven has cooled down to less than 300 °C.
 pyrolysis does not start. A signal sounds.	The shelves are still in the oven.	Take any accessories, ovenware and shelves out of the oven.
rrr appears in the display.	Power cut	Reset the clock.
Er7 appears in the display.	The oven lock/release mechanism is not working.	Contact the after-sales service.
Err appears in the display.	The temperature sensor is faulty.	Contact the after-sales service.

Repairs may only be carried out by fully trained after-sales service technicians.

Incorrect repairs may constitute serious hazards to the user.

Replacing the oven light

If the oven light fails, it must be replaced. 40 watt heat-resistant spare bulbs can be obtained from the after-sales service or specialist shops.
Only use these bulbs.

Method

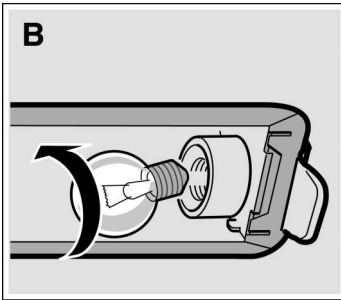
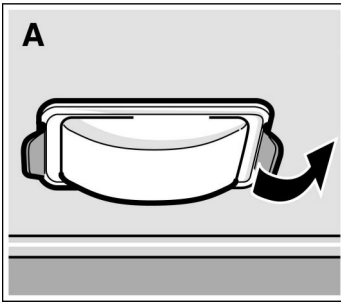

1. Switch off the oven fuse in the fuse box.
2. Place a tea towel in the cold oven to prevent damage.
3. Remove the glass cover. To do this, press back the metal tab with your thumb. Figure A.
4. Unscrew the bulb and replace it with one of the same type. Figure B.
5. Fit the glass cover back on. To do this, insert it on one side and press firmly on the other side. The glass cover will now click into place.
6. Remove the tea towel and switch the fuse back on.

Replacing the glass cover

The glass cover on the oven light must be replaced if it is damaged. Replacement glass covers may be obtained from the after-sales service. To this end, please specify the E number and FD number of your appliance.

After-sales service

Our after-sales service is there for you if your oven needs repairing. You will find the address and telephone number of your nearest after-sales service centre in the phone book. The after-sales service centres listed will also be happy to advise you of a service point in your local area.

E number and FD number

Please quote the E number (product number) and the FD number (production number) of your appliance when contacting the after-sales service. The rating plate containing these numbers is found on the right, on the side of the oven door. You can make a note of these numbers in the space below to save time in the event of your appliance malfunctioning.

E no.	FD no.
-------	--------

After-sales service ☎

Packaging and old appliances

Disposing in an environmentally-responsible manner



Unpack the appliance and dispose of the packaging in an environmentally-responsible manner.

This appliance is labelled in accordance with the European Directive 2002/96/EC concerning used electrical and electronic appliances (waste electrical and electronic equipment – WEEE).

The guideline determines the framework for the return and recycling of used appliances as applicable.

Tables and tips

This table contains a selection of dishes and the optimum settings at which to cook them. You can find out which types of heating and temperature are suitable for your dish, which accessories to use, and at which oven level the dish should be inserted. You will find a variety of tips about ovenware and preparation, and a small troubleshooting section in case anything should go wrong.

Note

You can buy the accessories and optional accessories mentioned from the after-sales service or specialist retailers.

Baking

Baking in baking tins



Notes

Always place the baking tin in the centre of the wire rack.

We recommend dark-coloured metal baking tins.

The baking time is increased if you use a light-coloured baking tin made of thin material or a glass dish, and the cake will not brown so evenly.

The temperature setting affects the degree of browning.

If a cake collapses after it is removed from the oven, select a longer baking time or set a lower temperature.

Baking on baking trays



Push the baking tray into the oven with the sloping edge facing towards the oven door.

Push the accessory carefully into the oven to prevent damage.

Always push the baking trays into the oven as far as the stop.

Only use original baking trays.

Baking in tin-plate tins

- | | |
|--|----------------|
| <input checked="" type="checkbox"/> CircoTherm hot air | shelf height 1 |
| <input type="checkbox"/> Top/bottom heating | shelf height 1 |

If the cake is too dark underneath:

Check the shelf height. Shorten the baking time and select a lower temperature.

If the cake is too light underneath:

Check the shelf height. Lengthen the baking time and select a lower temperature.



Or use a black baking tin.



Do not place baking tins or tall items of food directly in front of the rear wall of the oven.

Baking table

The details in the table are guidelines that apply to enamelled and dark-coloured baking tins. The values may vary depending on the type and amount of dough/mixture and on the baking tin. Observe the notes in the table about preheating.

We recommend that you set the lower of the specified temperatures the first time. This will generally allow more even browning. If you are baking according to your own recipe, use similar recipes in the table as a guide.

Baked goods	CircoTherm hot air 			Top/ bottom heating 	
	Level	Temp. in °C	Cooking time in minutes	Level	Temp. in °C
Sponge mixture					
Cakes on baking trays with topping					
1 tray	1	160-170	30-45	3	170-180
2 trays	1 + 3	150-160	45-50	-	-
Cakes in round tins/boxes	1	160-170	60-80	2	160-170
Fruit flan case	1	160-170	20-35	2	170-180
Shortcrust pastry					
Cakes on baking trays with a dry topping e.g. crumble					
1 tray	1	160-170	40-65	3	180-190
2 trays	1 + 3	160-170	60-75	-	-
Cakes on baking trays with a moist topping e.g. egg custard					
1 tray	1	150-170	60-80	-	-
Cakes in tins	1	160-170	60-100	2	170-180
Fruit flan case (preheat)	1	160-170	20-35	2	190-200

Baked goods	CircoTherm hot air 			Top/ bottom heating 	
	Level	Temp. in °C	Cooking time in minutes	Level	Temp. in °C
Sponge					
Swiss roll (preheat)	1	180-190	10-15	3	200-210
Fruit flan case	1	160-170	20-30	2	170-180
Sponge flan (6 eggs)	1	160-170	30-45	2	160-170
Sponge flan (3 eggs)	1	170-180	20-35	2	170-180
Yeast dough					
Cakes on baking trays with a dry topping e.g. crumble					
1 tray	1	170-180	35-50	3	180-190
2 trays	1 + 3	170-180	45-60	-	-
Cakes on baking trays with a moist topping e.g. egg custard					
1 tray	1	150-170	60-80	3	170-190
Yeast sponge ring or plaited loaf (500 g flour)	1	160-170	35-45	3	170-180
Cakes in shallow baking tins	1	160-170	30-45	2	170-180
Cakes in deep baking tins	1	160-170	30-45	2	170-180
Small baked products					
Meringue	1	80	100-130	3	80-90
Puff pastry (preheat)					
1 tray	1	180-200	20-30	3	200-210
2 trays	1 + 3	180-200	25-35	-	-
Choux pastry (preheat)					
1 tray	1	180-200	25-35	3	200-210
2 trays	1 + 3	180-200	30-40	-	-
Sponge mixture (e.g. muffins)					
1 tray	1	150-160	20-30	2	170-180
2 trays	1 + 3	160-170	25-35	-	-
Shortcrust pastry (e.g. butter biscuits)					
1 tray	1	140-150	15-20	3	140-150
2 trays	1 + 3	140-150	15-20	-	-
3 trays	1+3+4	140-150	20-25	-	-

Baking with the Pizza setting

The details in the table are guidelines that apply to enamelled and dark-coloured baking tins. The values may vary depending on the type and amount of dough/mixture and on the baking tin. Observe the notes in the table about preheating.

We recommend that you set the lower of the specified temperatures the first time. This will generally allow more even browning. If you are baking according to your own recipe, use similar recipes in the table as a guide.

The information applies to dishes placed in a cold oven. Observe the instructions on preheating.

Pizza setting

	Ovenware	Level	Temp. in °C	Cooking time in minutes
Meal				
Pizza	Baking tray	1	180-200	30-40
Savoury flan (preheat)	Baking tray	1	200-220	15-20
Tart	Tart tin or springform cake tin made from tin plate	1	190-210	35-50
Quiche	Tart tin or springform cake tin made from tin plate	1	190-200	40-50
Cheesecake	Springform cake tin	1	160-170	60-80
Swiss flan	Baking tray	1	210-230	40-50
Strudel	Baking tray	1	190-210	40-50
Frozen ready meals*				
Pizza with thin base	Wire rack covered with baking paper	1	190-210	10-20
Pizza with deep-pan base	Wire rack covered with baking paper	1	180-200	15-25
Potato products (e.g. chips)	Universal pan	1	200-220	15-25
Baked goods (e.g. bread rolls)	Wire rack covered with baking paper	1	200-220	5-15
Strudel	Baking tray	1	200-220	25-45

Baking tips

You wish to cook to your own recipe.

Refer to the instructions in the tables for similar types of food.

How to check that a sponge cake is cooked properly.

Approximately 10 minutes before the end of the baking time given in the recipe, pierce the tallest point of the cake with a cocktail stick. The cake is done if the cocktail stick comes out clean.

The cake collapses.

Next time, use less liquid or decrease the oven temperature by 10 degrees. Observe the cooking times in the recipe.

The cake has risen in the centre but is lower at the edges.

Do not grease the sides of the springform cake tin. As soon as the cake is done, carefully loosen the cake around the edges using a knife.

The cake is too dark at the top.

Insert it at a lower level in the oven, select a lower temperature and cook the cake a little while longer.

The cake is too dry.

Use a toothpick to make small holes in the finished cake. Then drizzle fruit juice or alcohol over the top. Next time you should decrease the temperature by around 10 degrees and reduce the baking times.

The bread or cake (e.g. cheesecake) looks fine, but is soggy on the inside (soft, with watery areas).

Next time you should add a little less liquid and cook for a little longer at a lower temperature. Cakes with fruit topping: Precook the base first of all. Sprinkle with almonds or breadcrumbs and then place the topping over this. Please observe the recipe and the baking times.

The cake is unevenly browned.

Select a slightly lower temperature to ensure that the cake is baked more evenly. Baking paper that protrudes over the food can affect the air circulation. For this reason, always cut the baking paper to fit the baking tray.

The cake is unevenly browned when using CircoTherm hot air .

Check the shelf height.

You were baking on several levels. The food on the top baking tray is darker than that on the bottom baking tray.

Always use CircoTherm hot air  when baking on several levels. Baking trays that are placed in the oven at the same time will not necessarily be ready at the same time.

Condensation forms when baking cakes containing fresh fruit.

Baking may result in the formation of water vapour, which escapes via the door. The steam may settle and form water droplets on the control panel or on the fronts of adjacent units. This is a normal physical process.

Meat, poultry, fish

Ovenware

You may use any heat-resistant ovenware. The universal pan is also suitable for larger roasts.

Always place the ovenware in the centre of the wire rack.

It is best to place hot glass dishes on a dry kitchen towel after removal from the oven. The glass could crack if placed on a cold or wet surface.

Roasting

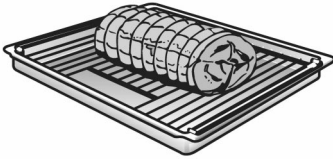

Place the wire rack in the universal pan and slide them in at the same shelf height.

The roasting result depends on the type and quality of the meat.

Depending on the size of the joint, add 2 or 3 tablespoons of liquid to lean meat and 8 to 10 tablespoons of liquid to pot roasts.

Turn pieces of meat halfway through the cooking time.

When the roast is ready, turn off the oven and allow it to rest for an additional 10 minutes. This allows better distribution of meat juices.

Roasting on the roasting sheet

(available as an accessory from specialist retailers)



Place the roasting sheet in the universal pan. The roasting sheet reduces level of soiling in the oven.

Dripping fat and meat juices are caught in the universal pan.

If you are using the roasting sheet, you can set a slightly higher temperature than specified if you want the roast to be particularly crispy.

Grilling



**Care is required when grilling.
Keep children at a safe distance.**

Always grill with the oven door closed.

The pieces of food you are grilling should be of equal thickness. They should be at least 2 to 3 cm thick. This will allow them to grill evenly and prevent them from drying out. Do not add salt to the steaks until they have been grilled.

Always use the wire rack and the universal pan.

Place the wire rack in the universal pan. Slide them in at the specified shelf height.

Place the food to be grilled directly on the wire rack. If you are grilling a single piece, it is best to place it in the centre of the wire rack.

Turn the food over after two thirds of the specified time has elapsed.

The grill element switches on and off continually. This is normal.



The weights indicated in the table refer to oven-ready poultry (without stuffing).

When cooking duck or goose, pierce the skin on the underside of the wings to allow the fat to escape.

Poultry will turn out particularly crispy and brown if you baste it towards the end of the roasting time with butter, salted water or orange juice.

Roasting table



The values in the table are average values.
The values may vary depending on the type and amount of food and on the ovenware.



Roast	CircoTherm hot air 		Cooking time in minutes	Top/ bottom heating 	
	Level	Temp. in °C		Level	Temp. in °C
Pork					
Joint with rind (e.g. shoulder or knuckle)	1	160-170	100-130	2	200-220
Joint/rolled joint	1	160-170	90-120	2	190-210
Smoked pork	1	160-170	70-80	2	190-210
Pork fillet	1	170-180	30-45	3	200-230
Meat loaf	1	170-190	60-70	2	190-210
Beef					
Fillet	1	180-190	45-65	2	200-220
Roast beef (pink)	1	180-190	30-45	2	200-220
Veal					
Joint/breast	1	160-170	90-120	2	180-200
Knuckle	1	160-170	100-130	2	190-210
Lamb					
Joint	1	180-190	70-110	2	200-220
Back	1	160-170	90-120	2	200-220
Poultry					
Chicken, 1 kg	1	170-180	60-70	2	200-220
Duck	1	160-170	90-120	2	190-210
Goose, 4 kg	1	150-160	130-180	2	180-200
Game					
Roe venison saddle	1	160-170	90-120	2	200-220
Roe venison joint	1	160-170	90-120	2	190-210
Wild boar/red deer venison joint	1	160-170	100-120	2	190-210
Fish	1	160-170	30-40	2	180-200

Grilling table

The values in the table are average values.
The values may vary depending on the type and amount of food and on the ovenware.

When using Thermo grill, turn large joints half way through the cooking time. When using the centre-area and full-surface area grill, turn food two thirds of the way through.

Grilled food		Level	Temperature in °C	Cooking time in minutes
CircoTherm hot air 				
Pork				
Steak (preheat)		1	180-190	15-20
Knuckle (with roasting sheet up to 190 °C)		1	170	100-130
Beef				
Steak (preheat)		1	190	approx. 15
Mince				
Steak		1	180-190	25-30
Chicken				
		1	170-180	60-70
Thermo grill 				
Pork				
Joints with rind	2 kg	2	170-190	130-140
Poultry				
Half chicken, 1-3 pieces	approx. 400 g per piece	2	200-220	40-50
Whole chicken, 1-3 pieces	approx. 1 kg per piece	2	200-210	55-65
Goose	approx. 4 kg	2	150-170	140-160

Grilled food	Level	Temperature in °C	Cooking time in minutes
Full surface-area grill  / centre-area grill 			
Pork			
Fillet steaks (2-2.5 cm)	4	max.	15-20
Shoulder steaks	4	250	20-25
Sausages	4	250	10-15
Beef			
Fillet steaks	4	max.	15-20
Tournedos	4	max.	15-20
Fish			
Small fish	4	220	20-25
Toast			
with topping	4	max.	6-9

Tips for roasting and grilling

The table does not contain information for the weight of the roast

Select the next lowest weight from the instructions and extend the time.

How can you tell when the roast is ready?

Use a meat thermometer (available from specialist shops) or carry out a "spoon test". Press down on the roast with a spoon. If it feels firm, it is ready. If the spoon can be pressed in, it needs to be cooked for a little longer.

The roast is too dark and the crackling is partly burnt.

Check the shelf position and temperature.

The roast looks good, but the juices are burnt.

Next time, use a smaller roasting dish or add more liquid.

The roast looks good, but the juices are too clear and watery.

Next time, use a larger roasting dish or add less liquid.

Steam rises from the roast when the juice is basted.

Use circo-roasting instead of top/bottom heating. This prevents the bottom of the roast from becoming too hot, thereby producing less steam.

Defrosting and cooking using hot air

Important notes

For defrosting and cooking frozen products, only use hot air mode.

For all frozen food, always follow the instructions of the producer.

When defrosted, frozen products (especially fish) normally need shorter cooking times than fresh products, because freezing acts as a sort of pre-cooking.

If **frozen meat** is placed in the oven, overall cooking time increases by the defrosting time.

Always defrost **frozen poultry** before cooking so the giblets can be removed.

Cook **frozen fish** at the same temperature as fresh fish.

Large numbers of **frozen ready meals** in aluminium containers can be put in the oven at the same time.

Shelf positions

For 1 sheet: shelf position 1

For 2 sheets: shelf position 1+3

Cooking time information is based on average values. Actual cooking time is influenced by the shape and amount of frozen products.

Defrosting

Defrost **raw frozen products or food from a freezer** at 50 °C.

Higher defrosting temperatures may cause the food to dry out.

Defrost packaged frozen dishes in **aluminium foil or in closed aluminium containers** at 130-140 °C.

Defrost and warm frozen baked goods at 100-140 °C. Spread bread loaves, bread rolls or other leavened food with a thin layer of water to produce a nicer crust.

Defrost **dry frozen cakes on baking sheets** at 160-170 °C for 20-30 minutes.

Defrost **moist frozen cakes** (with fruit filling) at 160-170 °C for 30-50 minutes. Also wrap the cakes in aluminium foil, so that the filling does not dry out.

Defrost and toast **frozen toast** (with topping) at 160-170 °C for approx. 20 minutes.

Frozen pizza:

Please follow the instructions of the producer.

Defrost setting

Especially suited to delicate cakes (e.g. cream gateauxs).

1. Turn the function selector to the .
2. Turn down the oven temperature using the temperature selector, until --- appears on the display.
The fan on the oven back wall runs even when no heating element is activated.

Defrost cakes for 25-45 minutes depending on the size and type.

Then remove it from the oven and leave it to continue defrosting for a further 30-45 minutes.

For small quantities (slices) the in-oven defrosting time is reduced to 15-20 minutes, and the time out of the oven to 10-15 minutes.

Preserving

Preparation

The jars and rubber sealing rings must be clean and intact. Use jars of the same size if possible. The instructions in the table refer to round 1-litre jars. Caution Do not use larger or taller jars. The lid could crack.

Only use perfectly fresh fruit and vegetables. Wash them thoroughly.

Pour the fruit or vegetables into the jars. Wipe clean the tops of the jars again if necessary. They must be clean. Place a wet rubber sealing ring and lid on each jar and lock the jars using clamps.

Do not place more than six jars in the oven.

The times specified in the tables are guidelines only. They can be influenced by the room temperature, the number of jars and the amount and temperature of the jar contents. Before you change settings or switch off the appliance, make sure that the contents of the jars are actually bubbling.

Inserting glass jars

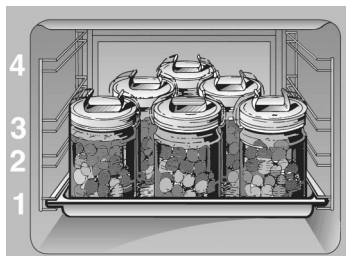

Slide the universal pan in at **shelf height 1**.

Position the preserving jars in a triangle. Maintain a distance of approximately 5 cm between the jars and the rear wall of the oven.

Position the preserving jars in the universal pan so that they do not touch each other.

Pour ½ litre of hot water (approx. 80 °C) into the universal pan.

Remove the jars

Place the jars on an absorbent cloth. Cover them and protect them from draughts.

Do not undo the clips until the jars have cooled down.

Fruit, gherkins and tomato purée

- 1 Insert the jars (see above).
- 2 Select **CircoTherm hot air**  and set to **approx. 160 °C**.
- 3 The rear jar and the right-hand jar in the second row start to bubble first.
Jars containing ½+1 l after approx. 50 minutes.
Jars containing 1½ l after approx. 60 minutes.
As soon as the other jars start to bubble, switch off the oven.
- 4 Leave the jars in the closed oven for a few minutes:
 - Raspberries, strawberries, cherries, gherkins **5-10 minutes**
 - Other fruit **10-15 minutes**
 - Tomato purée, apple purée **15-20 minutes**

Vegetables (except gherkins)

- 1 Insert the jars (see above).
- 2 Select **CircoTherm hot air**  and set to **approx. 160 °C**.
- 3 The rear jar and the right-hand jar in the second row start to bubble first.
Jars containing ½+1 l after approx. 50 minutes.
Jars containing 1½ l after approx. 60 minutes.
As soon as the other jars start to bubble, turn the oven temperature down to **100 °C**.
- 4 Allow the jars to continue boiling in the closed oven for **approx. 60 minutes**.
Switch off the oven.
Leave the jars in the oven for approximately another 15-30 minutes.

Energy saving tips

Only preheat the oven if it specifies in the recipe or in the table in the instruction manual that you should do so.

Use non-stick, black painted or enamelled tins. They absorb the heat especially well.

If you have several cakes to bake it is best to bake them one after the other. The oven is still warm. This shortens the baking time for the second cake. You can also put two baking tins in one after the other.

For long cooking times, the oven can be switched off 10 minutes before the end of the cooking time and the remaining heat can be used to finish the cooking.

Acrylamide in foodstuffs

Which foods are affected? Acrylamide is mainly produced in grain and potato products heated at high temperatures, such as potato crisps, chips, toast, rolls, bread, baked goods (biscuits, gingerbread, cookies).

Tips for keeping acrylamide to a minimum when preparing food

General

Keep cooking times to a minimum.
Cook meals until they are golden brown, not too dark.
Large, thick pieces of food contain less acrylamide.

Baking

With top/bottom heating, maximum 200 °C, with CircoTherm hot air, maximum 180 °C.

Biscuits

With top/bottom heating, maximum 190 °C, with CircoTherm hot air, maximum 170 °C.
Egg white and egg yolk reduce the formation of acrylamide.

Oven chips















Spread out a single layer evenly on the baking tray. Bake at least 400 g per baking tray so that the chips do not dry out.

Test dishes

In accordance with DIN 44547 and EN 60350

Baking

Observe the instructions on preheating. The values in the table are valid where rapid heat up  is not in use.

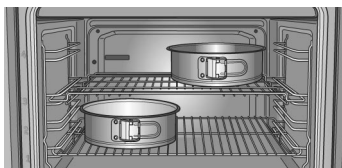

Meal	Type of heating	Level	Temp. in °C	Cooking time in minutes
Viennese whirls (preheat)	 Top/bottom heating	3	140-150	25-35
	 CircoTherm hot air	1	140-160	20-35
	 CircoTherm hot air	1 + 3	140-150	25-35
	 CircoTherm hot air	1 + 3 + 4	140-150	25-45
Small Cakes	 Top/bottom heating	3	160-170	25-35
	 CircoTherm hot air	1 + 3	160-170	25-35
	 CircoTherm hot air	1 + 3 + 4	150-160	30-40
Sponge base (preheat)	 Top/bottom heating	2	160-170	25-35
	 CircoTherm hot air	1	160-170	25-35
Yeast cakes on a baking tray	 Top/bottom heating	3	170-180	50-65
	 CircoTherm hot air	1	160-170	50-60
	 CircoTherm hot air	1 + 3	160-170	60-70
German apple pie	 Pizza setting	1	170-180	65-75
	Place tins next to each other on the wire rack			
Apple cake with topping (preheat)	 CircoTherm hot air	1 + 3	170-180	60-75

Insert tins so that they are diagonally offset.



Grilling

The values in the table apply to dishes placed in a cold oven.

Meal	Type of heating	Level	Temp. in °C	Cooking time in minutes
Toast (preheat for 10 minutes)	 Full-surf. area grill Universal pan with flat wire rack	4	275	½-1
Beef steaks, 12 pieces	 Full-surf. area grill Universal pan with deep wire rack	4	250	1. side: 11-15 2. side: 9-13