



MAKERS WARRANTY



# Cooktop

Model No: T2766NOAU

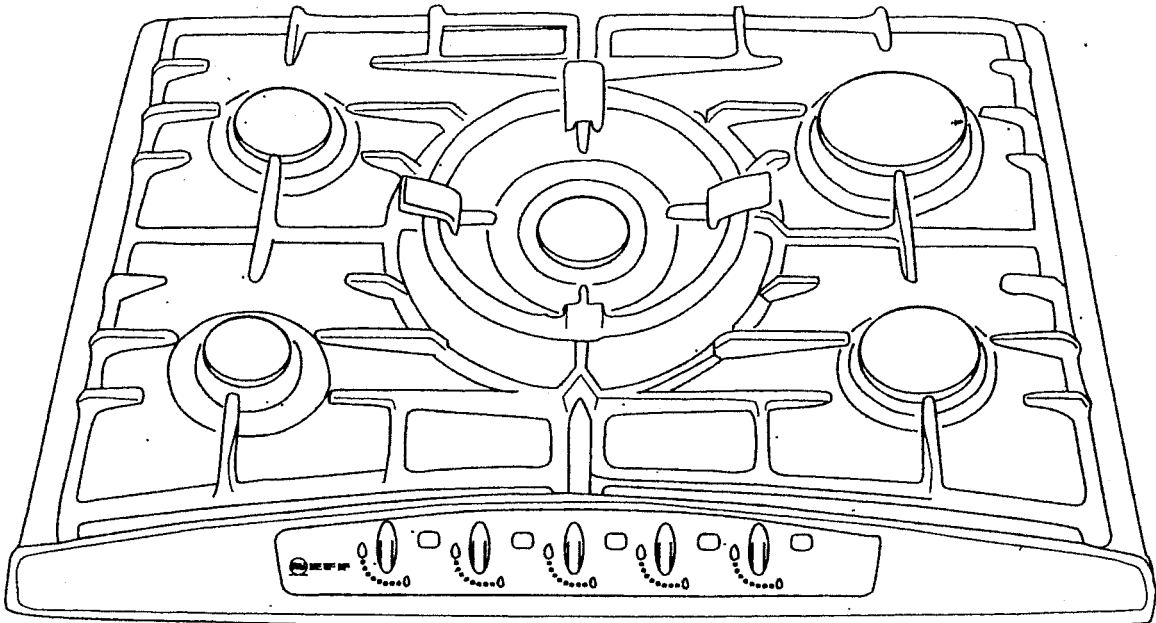

---

USER INSTRUCTIONS

---

INSTALLATION INSTRUCTIONS

---

MAINTENANCE INSTRUCTIONS

---

This cooktop is for use with Natural and Propane gases  
Leave these instructions with the owner

---

Dear customer,

We would like to thank and congratulate you for your choice. This practical modern appliance has been made using materials of the highest quality, which have been put through the strictest of Quality Controls during manufacture and meticulously tested to ensure that they meet all of your cooking demands. We kindly ask you to **read and follow these simple instructions** in order to guarantee first-class results from the very start. This booklet contains **important information** not only concerning use, but also concerning your own personal safety and maintenance of the appliance.

Our products need to be carefully packed to protect them during transportation. All the material used for packing is considered essential for this purpose and is also completely recyclable. You too can contribute towards protecting the environment by disposing of this material at your nearest recyclable refuse collection point. Do not dispose of used cooking oil down the kitchen sink. Oil may seriously damage the environment. Dispose of it in a closed container at your nearest collection point or, failing this, dispose of it in your rubbish bin. Although this last solution is far from perfect, your oil will be taken to a controlled refuse dump where it will not be allowed to pollute water. You and your children will appreciate it. Render your old appliance useless before disposing of it at your nearest recyclable refuse collection centre. Your local authority will be pleased to inform you where your nearest centre is.

# CONTENT

---

Contents .....	3
Safety considerations .....	4
For your safety .....	4
What to do if yo smell gas .....	4
Warnings .....	4
Installation .....	6
Preparing to install.....	6
Clearances .....	7
Installation of cooktop into Kitchen bench.....	7
Installation procedure.....	7
Connection .....	8
Electrical connection .....	8
Gas connection.....	8
Conversion front Nat. Gas to Propane Gas .....	9
To change injectors .....	9
Injector size chart.....	9
Minimum flame adjustment.....	10
Operating instructions .....	11
Burner location.....	11
Burner ignition & control.....	11
User instructions.....	12
Boiling burners .....	12
Wok trivet .....	12
Wire coffee support.....	12
Cleaning and care .....	13
Do's .....	13
Don't.....	13
Service .....	14
Trouble shooting .....	14
Wiring diagram .....	15
Service contact telephone numbers .....	15

# Safety considerations

---

## For your safety

- If the information in this manual is not followed exactly, a fire or explosion may result causing property damage, personal injury or death.
- Do not store articles on or against this appliance.
- Do not store flammable material near this appliance.
- Do not spray aerosols in the vicinity of this appliance while it is in operation.

## What to do if you smell gas

- Do not try to light the appliance.
- Do not touch any electrical switch; do not use any phone in your building.
- Immediately call your gas supplier from a neighbour's phone. Follow the gas supplier's instructions.
- If you cannot reach your gas supplier, call the fire department.
- Installation and service must be performed by an authorised person.

## Warnings

1. Do not allow the flame to extend beyond the edge of the cooking utensil. This instruction is based on safety considerations.
2. Do not forget that the unit becomes hot when in use. Common sense is important. Just because the flame is out, does not mean parts cannot still be hot.
3. This appliance shall not be used for space heating. This instruction is based on safety considerations.
4. Be sure to disconnect the electrical supply before disassembly of the appliance.
5. Keep the appliance area clear and free from combustible materials, gasoline and other flammable vapours and liquids.
6. This appliance must be installed in a position with the proper level of ventilation. Do not obstruct the flow of combustion and ventilation air.
7. Cabinets installed above the gas cooktop must have a minimum clearance of 650 mm (24").
8. The gas pressure regulator supplied with the appliance must be installed in line with the gas pipe. (N.G. only)

---

9. For pressure testing in excess of 3.5 kPa (1/2 psig) the appliance and its individual shutoff valve must be disconnected from the gas supply piping system.

10. Important. When using a very large pot, leave a gap of at least 50 mm (2") to avoid damaging any parts in bench top wood, plastic or other non-heat resistant materials. Never leave oil or hot fat unattended.

11. The surfaces on heating and cooking appliances get hot when in use. Be careful. **Keep children away from the appliance.**

12. Only use your appliance for the preparation of food and **never** for room-heating purposes.

13. This appliance leaves the factory set for the gas supply indicated on the characteristics plate. **Call the Service Centre** if it needs to be altered.

14. Do not tamper inside the appliance. If necessary, call your local **Service Centre**.

15. Overheated fat or oil can easily catch fire. Never leave the appliance unattended when cooking food with fat or oil, e.g. chips.

16. Never pour water on burning fat or oil. **DANGER OF BURNS!** Cover the receptacle to smother the flames and turn the hob off.

17. In the event of a fault, cut the gas and electricity supplies to the appliance. Call our **Service Centre** to repair the fault.

18. Do not use unstable or uneven-based receptacles on cooking plates or burners. They may accidentally tip over.

19. If a gas supply knob/valve jams, do not force it. Call your official Service Centre immediately for them to repair or replace it.

20. The illustrations used in this booklet are only intended as a guide.

Note: To avoid jeopardising the electrical safety of the appliance, it is forbidden to use high-pressure or steam jet cleaning devices.

**SHOULD THE RELEVANT CONDITIONS NOT BE PROPERLY SATISFIED, THE INSTALLER, AND NOT THE MANUFACTURER, SHALL BE HELD LIABLE.**

# Installation

## Preparing to install

This installation must conform with the following:

- Manufacturer's Installation instructions
- Local Gas Fitting Regulations
- Municipal Building Codes,
- AGA Installation Code for Gas Burning Appliances. (AS 5601/AG 601)
- S.A.A. Wiring Code
- Local Electrical Regulations
- Any other statutory regulations

These built-in hobs are intended to be inserted in a benchtop cutout.

Only an officially authorised technician should connect the appliance.

Installation dimensions are shown in Fig.1

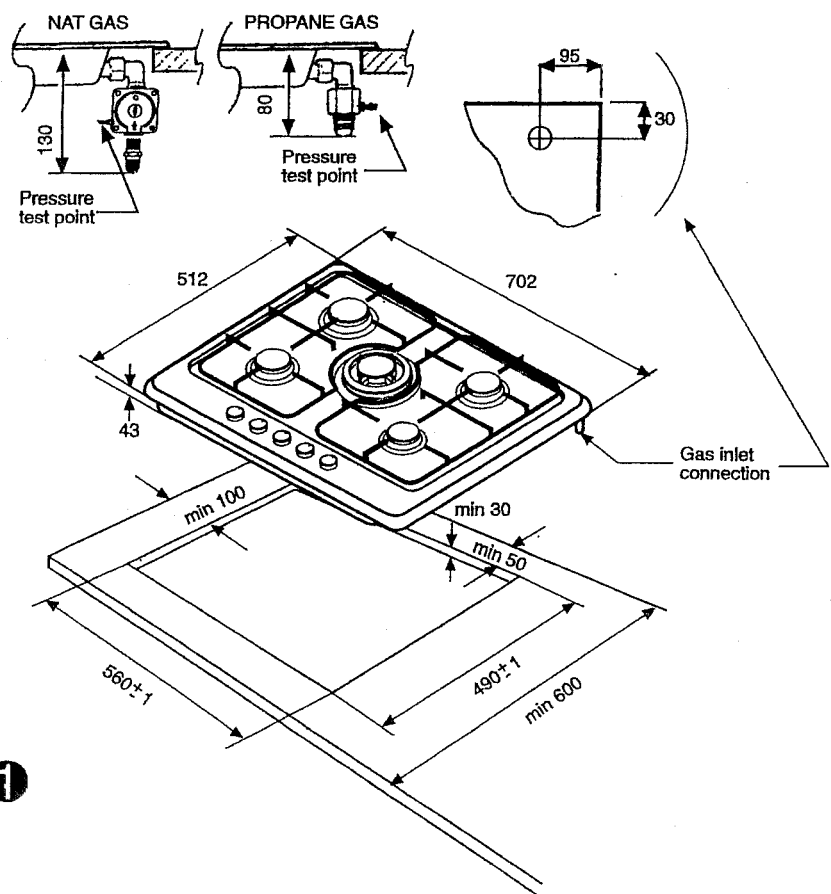

Before connecting the unit, check whether the local connection conditions (type of gas) are compatible with the unit's setting. Observe any special conditions imposed by local suppliers (utilities). The specifications of this cooktop are stated on the data label located on the bottom of the cooktop base.

## Clearances

A range hood fitted above the top must be installed according to the installation instructions for the range hood. A minimum distance of 650 mm is required for a range hood and 750 mm for an exhaust fan.

If the distance measured from the periphery of the nearest burner to any vertical surface is less than 200 mm, the surface shall be protected in accordance with clauses 5.12.1 & 5.12.1.2 of AS 5601/AG 601.

Leave a space at least 100 mm between any drawer, partition or oven that is installed underneath the cooktop.

Minimum thickness of benchtop is 30 mm. See Fig. 2.

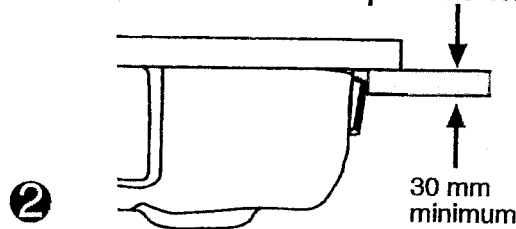

## Installation of cooktop into the kitchen bench

### Installation procedure:

1. For cutout dimensions and clearances refer Fig. 1.
2. The hotplate encloses a sealing tape. The selfadhesive seal supplied with the appliance has to be fixed to the lower edge of the hob. The seal keeps the entire work surface watertight and prevents spillage from leaking into cupboards underneath. Please ensure that the sealing tape is not disturbed during the installation process. Take the pressure clamps and fit them either side. Refer Fig.3.

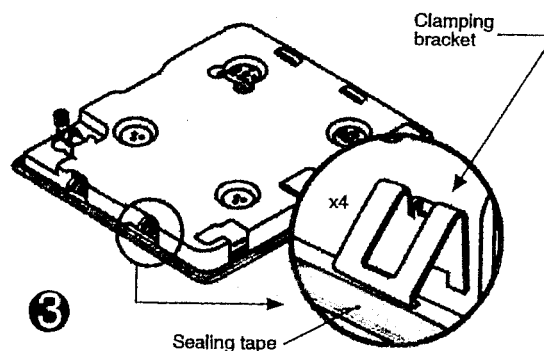

3. Place hotplate on top of the bench cut-out and press down firmly on all edges at the same time to ensure that the hob is resting on its entire perimeter.  
NOTE: If it is necessary to dismount the hob, press upwards only from underneath

## Installation continued

### Connection

#### Electrical:

An electrical 10 amp socket needs to be within 1 m of the hotplate to allow electrical connection. The socket must remain accessible after installation of the appliance.

#### Important note:

This appliance is connected to the mains (240 VAC) by means of the connecting lead which must be fixed to the kitchen unit to prevent it from coming into contact with hot parts of the hob (or an oven installed underneath).. When making this connection make sure that the lead cannot come into contact with hot parts of the hob.

Important: This appliance must be earthed.

#### Gas:

During the planning stage, consider the position of supply connections.

The hob must be connected to the gas supply with upstream connection of an isolation valve in accordance with the respectively valid regulations. We recommend that the isolation valve be fitted prior to the cooktop to enable isolation of cooktop from gas supply. The valve must be easily accessible at all times.

To find out the factory set gas type, see bottom of cooktop next to gas connection.

Remove plastic cap from gas supply line prior to installation.

Fit regulator (N.G.) or propane fitting (Propane) directly to the R $\frac{1}{2}$ " connection as per Fig. 4. and Fig. 5.

Direction of gas flow is indicated on the rear of the regulator.

For position of the inlet connection refer Fig. 1.

Make sure that all connections performed are free of leakage.

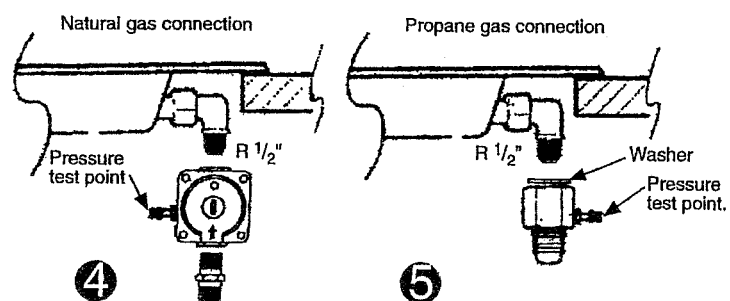

It should be expressly noted that we cannot accept any liability for direct or indirect damage caused by wrong connection, leakage or improper installation. When being repaired, the appliance must always be disconnected from the mains supply; if required, notify our customer service.

## Converting the cooktop from Nat. Gas to Propane Gas

### To change injectors

All work involved in installation, setting and adaptation to a different gas type must be carried out by authorised personnel from our Service Centre and must comply with current regulations and the conditions laid down by the local gas company.

Request change-over injectors from our customer service department (refer injector chart below for sizes).

Burner	Natural Gas		Propane Gas	
	Injector size (mm)	Hourly Gas Consumption (MJ)	Injector size (mm)	Hourly Gas Consumption (MJ)
Left Front (Wok)	0.90	4.0	0.5	3.25
Left Rear	1.18	6.5	0.67	6.25
Centre	1.70	14.0	0.97	13.25
Right Front	1.18	6.5	0.67	6.25
Right Rear	1.60	12.0	0.85	10.0

Before conversion the cooktop must be disconnected from the electricity and gas valves must be turned to the OFF position.

- 1 Remove the trivets, burner caps and burner heads. Refer Fig. 6.
- 2 Change the injectors using a 7-mm socket wrench and be sure to tighten them down properly so that they are fully airtight. Refer Fig. 7.
- 3 Re-assemble the burner component parts in reverse order.

NOTE: it is not necessary to adjust the primary air control on these burners.

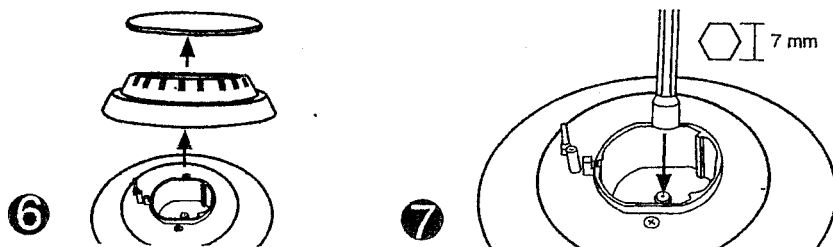

## Minimum flame adjustment

- 1 Turn the control knob to minimum.
- 2 Remove the control knob from the valve spindle. Refer Fig. 8.
- 3 Using a screwdriver carefully pry off the hard plastic seal. Refer Fig. 9.
- 4 Using a small screwdriver carefully remove the soft rubber seal. Refer Fig.10.
- 5 The adjustment screw is positioned at the rear lower section of the valve. Refer Fig. 11 & 12.
- 6 To adjust the minimum flame for N.G. replace the control knob onto the spindle, light the gas and turn the control knob to the small flame position. Screw the adjustment screw anti-clockwise to establish a minimum stable flame position. The flame should remain alight and not burn back to the injector when the valve is turned quickly from 'Full On' to the "Minimum flame" position and back a few times. To adjust the minimum flame position for LP Gas the screw must be fully tightened down clockwise.
- 7 Remove the control knob, replace the seals in reverse order and refit the control knob. Never dismantle the valve shaft: in the event of damage, change the entire valve.

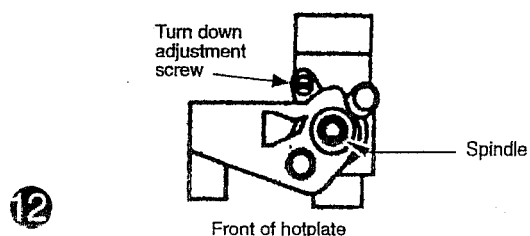
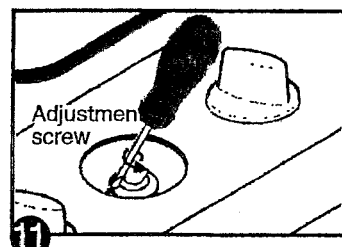
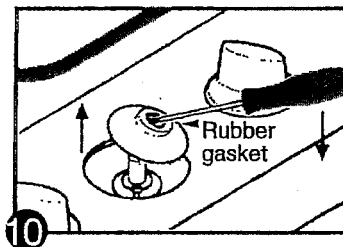
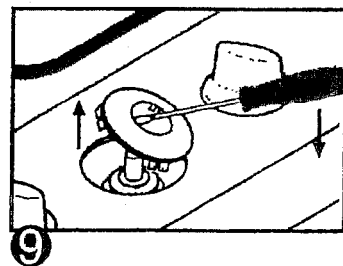
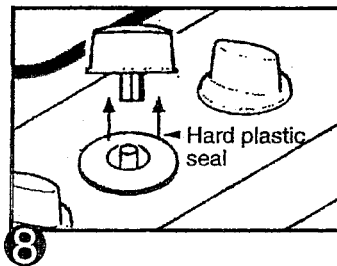

# Operating instructions

## Burner locations

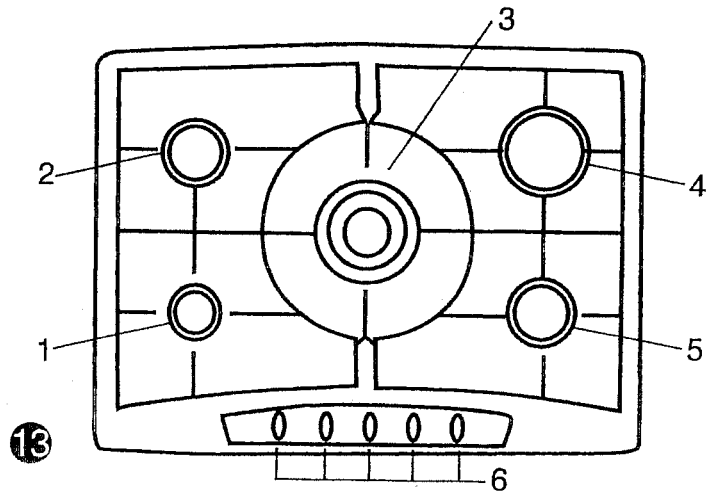

- |                  |                  |
|------------------|------------------|
| 1. Small burner  | 4. Large burner  |
| 2. Medium burner | 5. Medium burner |
| 3. Wok burner    | 6. Control knobs |

## Burner ignition & control

Depress control knob and turn anti-clockwise to "High flame" position. Hold the knob down for a few seconds until the flame ignites. Keep control knob depressed for a few seconds to activate the flame failure device. If ignition fails, depress knob again and wait for ignition. Turn anti-clockwise to set the flame to the desired intensity.

All burners are fitted with a flame failure device which shuts off the gas supply if the flame extinguishes for any reason. To re-ignite, wait 30 seconds for any unburnt gas to disperse before repeating the ignition procedure described above.

To turn off the gas supply to a burner turn the control knob clockwise to the "OFF" position. (Refer Fig. 14)

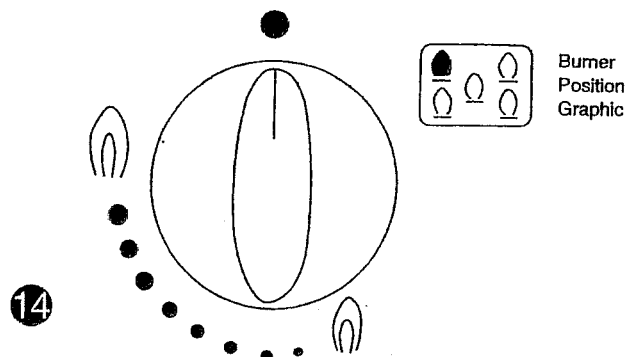

The control knob is used to adjust the flame of the gas burner.  
"Low flame" graphic= lowest output  
"High flame" graphic= highest output

# User Instructions

## Boiling burners

Use "High flame" setting to bring the pan to the boil, then adjust the flame between "High flame" and "Low flame" to maintain the required pan temperature.

### Important:

The use of a cooktop leads to the production of heat and moisture in the kitchen. For this reason make sure that the room is properly ventilated. Keep natural ventilation openings, such as windows, open or provide a mechanical ventilation device (e.g. a range hood or overhead exhaust fan). An orangy flame is normal and simply indicates the presence of salt in the atmosphere (from cooking). If the flame has yellow patches, this is not a fault (of any kind).

For safety and economic gas usage you should always use the correct pan on the correct burner. Flames should not protrude beyond the base of the pan. You will save energy, time and money by always placing the correct pan size on the correct gas ring. See fig. 15.

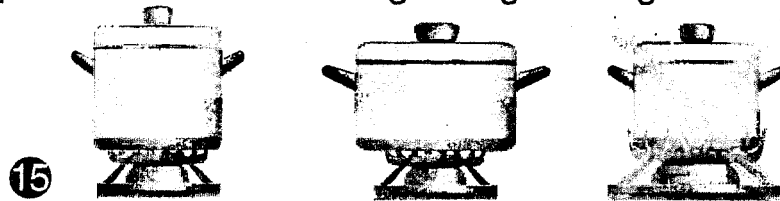

The chart below gives the correct pan usage for each burner.

Burner	Recomended pan diameter	Minimum pan diameter
Small burner	100-120 mm.	100 mm.
Large & wok burner	220-260 mm.	220 mm.
Medium burner	120-200 mm.	120 mm.

### Wok trivet

The hotplate is supplied with an extra wok trivet. This trivet must be used when using the wok burner for receptacles with diameters of more than 26 cm diameter, griddle plates and all kinds of concave receptacles such as woks, etc.

### Wire coffee support

This support is for use only with the small burner when supporting receptacles with a diameter of less than 10 cm.

The manufacturer cannot be held responsible for the non-use or misuse of these additional pan supports.

---

## Cleaning

### Do's

- Once the appliance is cold, clean it with a sponge and soapy water. Remove any spills immediately. This will avoid unnecessary effort later.
- Allow burners and trivets to cool down before cleaning them.
- The burners and trivets must be cleaned regularly to keep them in good condition. This is done by submerging them in soapy water and scrubbing them with a non-metal brush to keep the ports and slots free from obstructions so they give a perfect flame. Dry the burner caps and trivets whenever wet or damp.
- After cleaning and drying ensure that the burner heads and caps are replaced correctly on the burner body. Refer Fig. 6.
- The high temperatures generated by using the wok burner may cause the stainless steel hob of your hotplate to become discoloured over time. THIS IS NORMAL. Clean the hob with a product suitable for cleaning stainless steel.
- The trivets on your hob are fitted with rubber feet. Be careful when cleaning as they may be dislodged during cleaning, leaving the stainless steel hob unprotected and subject to surface scratching.
- The cleaning product suitable for stainless steel must not be used in the area surrounding the control knobs because you may remove the indications (serigraphy).

### Don't

- Never use abrasive products, sharp objects, steel scouring pads, knives, etc., to remove stubborn food remains from the hob surface, trivets and burners.
- Do not allow acidic products such as vinegar, lemon juice, etc., to come into contact with the hob.
- Your hob comes with a glass panel under the knobs. Do not use knives scrapers or similar utensils to clean the join with the metal.

# Service

## Trouble shooting chart

It is not always necessary to call the Service Centre. In some cases, you may be able to solve the problem yourself. This table contains some useful information.

**Important:**

Only authorised personnel from the Service Centre are qualified to work on the main gas and electric systems.

What's wrong	Possible cause	Solution
...If none of the electrical systems work.	<ul style="list-style-type: none"> <li>• Power turned off</li> <li>• Faulty fuse.</li> <li>• The automatic circuit breaker or mains differential has been triggered.</li> </ul>	<ul style="list-style-type: none"> <li>• Turn power on</li> <li>• Check the fuse in the main fuse box and replace if faulty</li> <li>• Check to see if the circuit breaker or a differential has been triggered in the mains supply box</li> </ul>
...If the electronic ignition system does not work.	<ul style="list-style-type: none"> <li>• There may be food or cleaning product particles between the spark plugs and the burners.</li> </ul>	<ul style="list-style-type: none"> <li>• The gap between the spark plug and the burner needs to be cleaned carefully.</li> </ul>
...If the flame on the burners is not evenly distributed.	<ul style="list-style-type: none"> <li>• The burner components have not been assembled properly.</li> <li>• The gas ports on the burners are dirty.</li> </ul>	<ul style="list-style-type: none"> <li>• Put the components in their correct positions.</li> <li>• Clean the gas ports on the burners.</li> </ul>
...If the gas flow does not seem normal or there is no gas flow at all.	<ul style="list-style-type: none"> <li>• The isolation valve is closed.</li> <li>• If the gas is supplied from a gas bottle, it may be empty.</li> </ul>	<ul style="list-style-type: none"> <li>• Open the isolation valve.</li> <li>• Replace the gas bottle with a full one.</li> </ul>
...If the kitchen smells of gas	<ul style="list-style-type: none"> <li>• One of the valves has been left open.</li> <li>• Possible leak on the gas bottle coupling.</li> </ul>	<ul style="list-style-type: none"> <li>• Check to see if a valve has been left open.</li> <li>• Check that the coupling on the gas bottle is in order.</li> </ul>
...If the safety cut-off devices on the different burners do not work.	<ul style="list-style-type: none"> <li>• The control knob has not been kept pressed in for long enough.</li> <li>• The burner ports are dirty.</li> </ul>	<ul style="list-style-type: none"> <li>• Once ignited, keep the control pressed in for a few seconds.</li> <li>• Clean the burner ports.</li> </ul>

## Wiring diagram

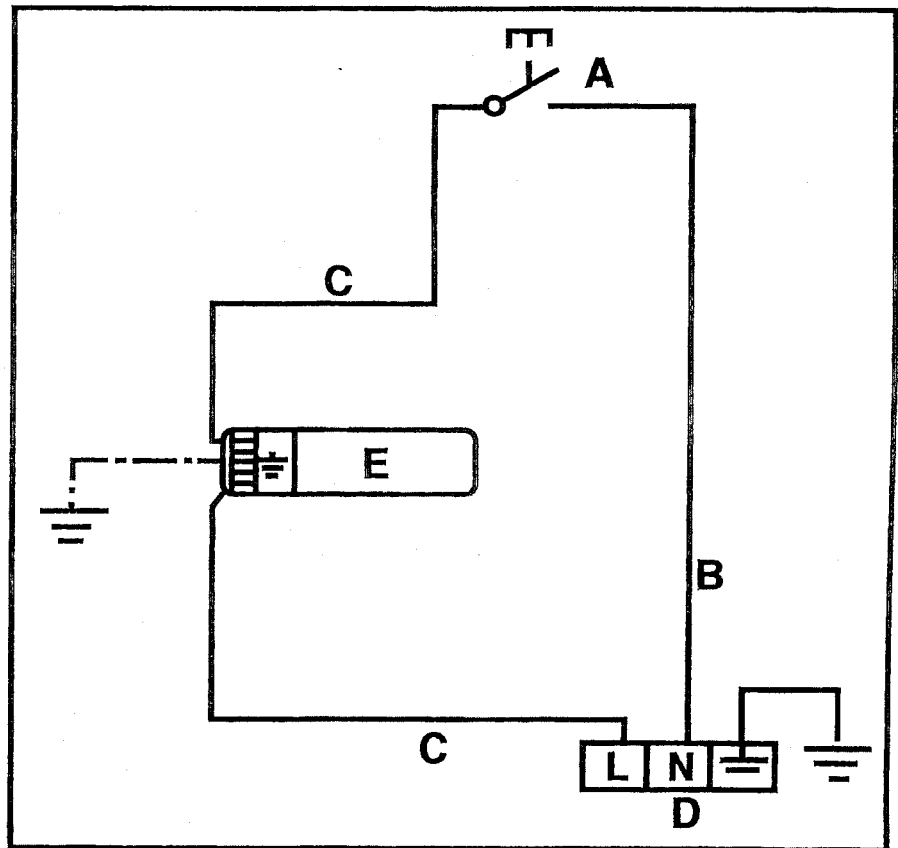

- A. Switch
- B. Blue wire
- C. Brown wire
- D. Terminal
- E. Ignition module

## Service agent

For service to this appliance please contact:

### **Sampford & Staff P/L**

421 Smith Street.

Frizroy, Vic, 3065.

Phone:

Vic/Tas (03) 9418 5888

NSW (02) 9331 8888

Qld (07) 3358 3000

S.A./N.T. (08) 8212 7000

W.A. (08) 9240 1288

A.C.T. (02) 6280 4177

Elsewhere 1800 334 887

E-mail [service@sampford.com.au](mailto:service@sampford.com.au)