

**How to connect up,  
build-in, set up, use and  
look after your  
U1524 oven**

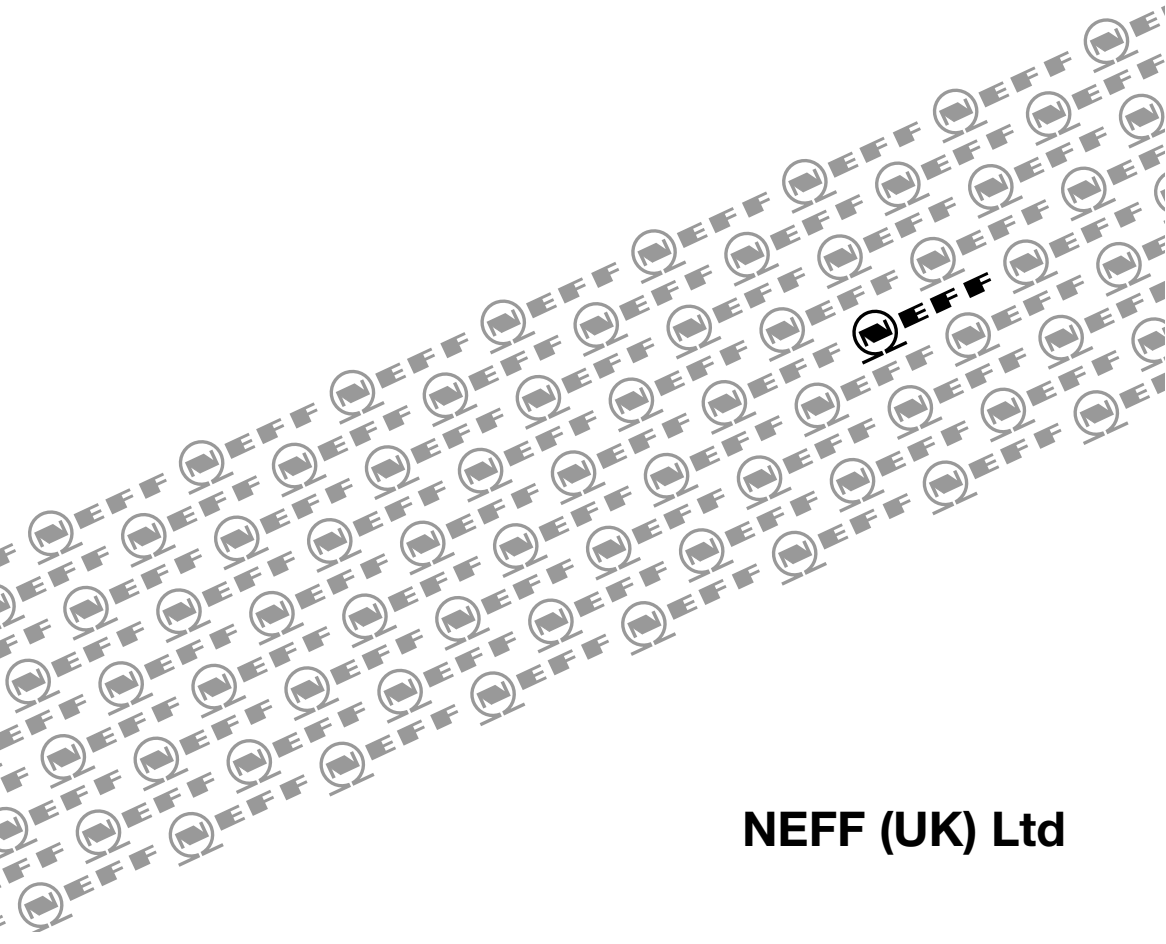

**NEFF (UK) Ltd**

# Table of contents

<b>Important Information</b> . . . . .	<b>3</b>	<b>Baking – Main oven</b> . . . . .	<b>21</b>
Packaging and old appliances . . . . .	3	<b>Cooking Tips and Helpful Hints</b> . .	<b>22</b>
Before installation . . . . .	4	<b>Roasting – Main oven</b> . . . . .	<b>23</b>
Safety information . . . . .	4	<b>Grilling – Main oven</b> . . . . .	<b>25</b>
Reasons for damage . . . . .	5	Circo-roasting . . . . .	26
<b>Your new cooker</b> . . . . .	<b>6</b>	Surface grilling . . . . .	26
The control panel . . . . .	6	<b>Switching the oven ON and OFF</b>	
<b>Main oven</b>		– Mini oven . . . . .	27
Description of Oven Features . . . . .	6	<b>Roasting – Mini oven</b> . . . . .	<b>28</b>
<b>Mini oven</b>		<b>Grilling – Mini oven</b> . . . . .	<b>29</b>
Temperature selector . . . . .	7	Surface grilling . . . . .	29
Function selector . . . . .	7	<b>Defrosting and Cooking</b>	
Press-down switches . . . . .	7	– <b>Main oven</b> . . . . .	<b>30</b>
Slide-in levels . . . . .	8	<b>Defrost – Main oven</b> . . . . .	<b>32</b>
<b>Accessories</b> . . . . .	<b>9</b>	<b>Dough proving setting</b>	
<b>Before using your Appliance</b>		– <b>Main oven</b> . . . . .	<b>32</b>
<b>for the first time</b> . . . . .	<b>10</b>	<b>Cleaning and Care</b> . . . . .	<b>34</b>
Preliminary cleaning . . . . .	10	Important cleaning basics . . . . .	34
Initial burn-in . . . . .	10	Catalytic oven surfaces . . . . .	36
Time of day . . . . .	10	AquaCleanse – Main oven . . . . .	37
<b>Electronic clock</b> . . . . .	<b>11</b>	Oven Cleaning – Mini oven . . . . .	39
The control panel . . . . .	11	Removing/installing	
Minute timer . . . . .	11	the oven door . . . . .	40
Automatic timer . . . . .	12	Inset rack . . . . .	41
Special functions . . . . .	13	<b>Service and Repair information</b> . .	<b>41</b>
<b>Description of Oven Features</b> . . . . .	<b>14</b>	<b>Trouble-shooting Guide</b> . . . . .	<b>43</b>
Main oven . . . . .	14		
Mini oven . . . . .	16		
<b>Switching the oven ON and OFF</b>			
– Main oven . . . . .	17		
<b>Safety features</b> . . . . .	<b>19</b>		
Locking the oven . . . . .	19		
Permanent lock . . . . .	20		
Automatic safety off function . . . . .	20		

## Assembly instructions

<b>For the installer</b>	
<b>and kitchen expert</b>	
<b>Important installation notes</b> . . . . .	<b>45</b>
<b>Installation of the built-in oven</b> . . .	<b>46</b>

---

# Important information



Before using your new appliance, please read these Instructions for Use carefully. They contain important information concerning your Personal safety as well as on use and care of the appliance.

The Instructions for Use apply to several versions of this appliance. Accordingly, you may find descriptions of individual features that do not apply to your specific appliance.

Please keep the operating and installation instructions in a safe place; this important documentation may also be of use to a possible subsequent owner.

---

## Packaging and old appliances

Your new appliance was protected by suitable packaging while it was on its way to you. All materials used for this purpose are environmentally friendly and can be recycled. Please make a contribution to protecting the environment by disposing of the packaging appropriately.

Old appliances are not worthless rubbish. Environmentally-conscious recycling can reclaim valuable raw materials.

Before disposing of your old appliance, please make sure that it is unusable, or label it with a sticker stating „Caution, scrap”.



This appliance is labelled in accordance with European Directive 2002/96/EG concerning used electrical and electronic appliances (waste electrical and electronic equipment – WEEE). The guideline determines the framework for the return and recycling of used appliances as applicable throughout the EU.

Up-to-date information on how to dispose of your old appliance and the packaging from the new one can be obtained from your retailer or local authority.

---

## Before installation

### Transport damage

Check the appliance after unpacking it. Do not connect the appliance if it has been damaged in transport.

### Electrical connection

The cooker may only be connected by an approved specialist. Losses resulting from damage caused by incorrect connection will invalidate warranty claims.

---

## Safety information

### Hot oven



This appliance is intended for domestic use only. Only use the cooker for food preparation.

Open the oven door carefully. Hot steam may escape. Never touch the internal surfaces of the oven or the heating elements. There is a risk of burning. Children must be kept at a safe distance from the appliance.

Never store combustible items in the oven.

Risk of fire. Never place flammable objects onto the hot plates. Fire hazard!

Never place cables of electronic devices onto the hot plates.

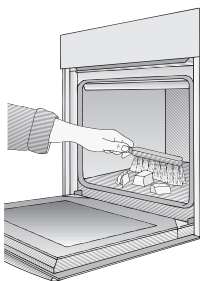

Never clamp leads of electrical appliances in the hot oven door. The insulation on the leads could melt. There is a risk of short-circuiting.

**Caution:** The extension rails heat up during oven operation. Use special care to avoid burns when extending the rails.

Remove all packaging remnants, e.g. polystyrene parts, from the oven.

### Repairs

Incorrectly done repairs are dangerous. There is a risk of electrocution.

Repairs may only be carried out by after-sales service technicians who have been fully trained by BSH.

If there is a fault, switch off the oven fuse at the fuse box.

Call the after-sales service.

---

## Reasons for damage

### **Baking tray, aluminium foil or dishes on the oven floor**

Do not place the baking tray on the oven floor.  
Do not cover it with aluminium foil.  
Do not place dishes on the oven floor.  
This will cause heat accumulation. The baking and roasting times will no longer be correct and the enamel will be damaged.

### **Baking paper**

If using circotherm, do not place greaseproof paper loosely in the oven (e.g. when heating the oven).  
The hot-air fan could draw in the paper which may damage the heater and fan.

### **Water in the oven**

Never pour water directly into a hot oven.  
This could damage the enamel.

### **Fruit juice**

When baking very moist fruit cakes, do not put too much on the baking sheet. Fruit juice dripping from the baking sheet leaves stains that cannot be removed.  
It is recommended that you use the deeper universal pan.

### **Cooling with the oven door**

Only leave the oven to cool with the door closed. Do not allow anything to become trapped in the oven door. Even if you only leave the oven door open slightly, the fronts of adjacent units may become damaged over time.

### **Very dirty oven seal**

If the oven seal is very dirty, the oven door will no longer close properly when the oven is in use.  
The fronts of adjacent units could be damaged.  
Keep the oven seal clean.

### **Using the oven door as a seat**

Do not stand or sit on the oven door.

### **Care and cleaning**

Do not use high-pressure cleaners or steam jets.

# Your new cooker

Here you will learn more about your new oven. The control panel and its switches and indicators are explained here. The heating modes and the accessories included with your oven will be explained here.

## The control panel

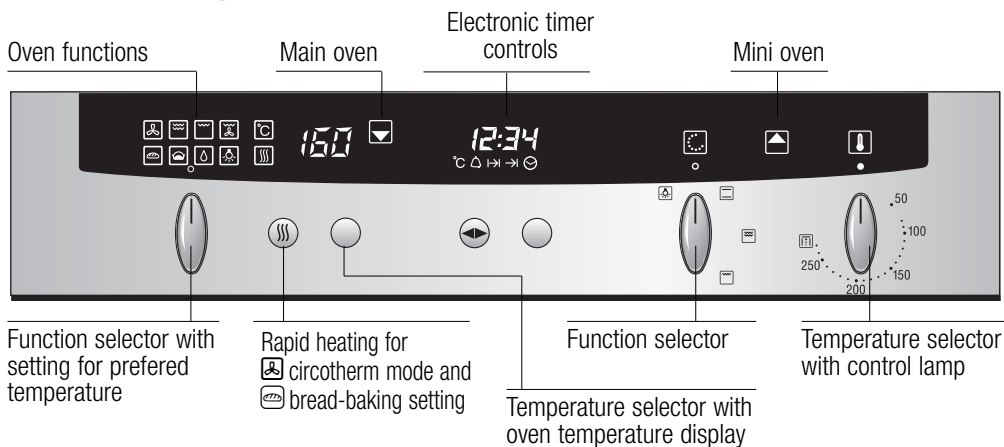

## Main oven

### Oven functions

- Circitherm
- Surface grilling, large area grill
- Surface grilling, small area grill
- Circo-roasting
- Bread-baking
- Dough-proving
- AquaCleanse
- Oven light
- Oven temperature
- Rapid heat up

### Note

The oven light switches on for every oven function.

Exception: Oven cleaning.

The indicator light for the oven temperature is lit red during the heating up phase and during reheating.

The indicator light goes out when the set temperature is reached.

Rapid heating can be selected for circitherm or bread-baking setting.

---

# Mini oven

## Temperature selector

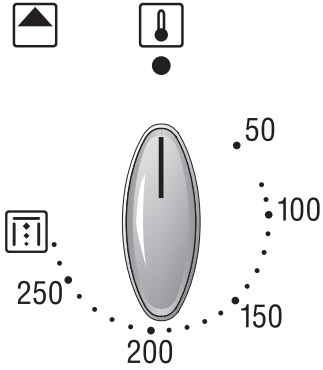

### Settings

**50–275** Temperature in °C.



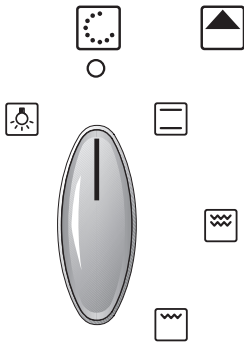

 Oven Cleaning

## Function selector



Use the function selector to select the type of heating for the oven.

### Settings

-  Oven light
-  Top/bottom heat  
(conventional heating system)
-  Large area grill
-  Small area grill

---

## Press-down switches

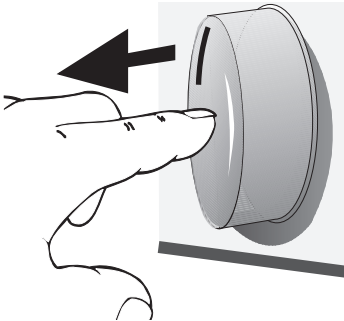

To engage and disengage, depress the switch, making sure that it is in OFF position.

## Slide-in levels

### Mini oven

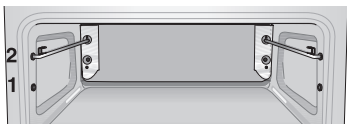

Your oven features 2 shelf positions.

**The shelf positions are counted from bottom to top.**

The numbers are marked in the oven.

### Main oven



Your oven features 4 slide-in levels. **The slide-in levels are counted from bottom to top.**

The numbers are marked in the oven.

When using **circotherm**, **do not use slide-in level »2«**, in order not to block air circulation.

The hook-in grilles and telescopic rails can be inserted at your preferred slide-in level. (Optional accessory available from your dealer).

# Accessories

Your appliance is supplied with:

Universal pan with grid



3 Grid



Additional accessories can be obtained from a specialist dealer. Before ordering, please check the Neff sales literature to confirm which of the following items are available in the UK:

Order no.

Universal pan	Z 1232 X0
Universal pan, non-stick	Z 1233 X0
Glas pane	Z 1262 X0
Soufflé pan	Z 1272 X0
Baking tray, aluminium	Z 1332 X0
Baking tray, enamelled	Z 1342 X0
Baking tray, non-stick	Z 1343 X0
Pizza tray	Z 1352 X0
Wire shelf, high/low	Z 1432 X0
Wire shelf, dose mesh	Z 1442 X0
Roasting tray	Z 1512 X0
Upgrade set – Single Telescope	Z 1784 X0
System steam cooker	N 8642 X0 EU
Pizza stone	Z 1912 X0
Universal oval roaster enamelled	Z 9930 X0

## Note:

The baking tray or universal pan may distort while the oven is operating. This is caused by major temperature differences on the utensil. These differences may occur if only one part of the utensil was covered or if deep-frozen food, e.g. pizza, was placed on the utensil.

The distortion will already subside again during baking, roasting or grilling.

---

# Before using your appliance for the first time

---

## Preliminary cleaning

Take the accessories out of the oven.

Remove all packaging remnants, e.g. polystyrene parts, from the oven.

1. Clean the appliance exterior with a soft moistened cloth.
2. Remove the hook-in grilles and telescopic rails from the oven.
3. Clean the oven and the accessories with a hot detergent solution.

---

## Initial burn-in

**Before using the appliance for the first time, you must set the current time on the electronic clock.**

Heat the empty oven for approx. 30 minutes. Select top and bottom heat at a setting of 240° C. During the initial burn-in phase, please open the kitchen windows to dissipate unpleasant odours.

---

## Subsequent cleaning

Clean the oven with a hot detergent solution. Install the hook-in grilles and telescopic rails.

---

## Time of day

### Setting the time



After connecting to the mains, or after a power failure, the display 0:00 will blink.

Press the ◀▶ button and set the current time with the rotary knob (e.g. 15:00 hours).

To correct the time, press the ◀▶ button until the Ⓜ symbol flashes.

Then set the time.

**Note:** The time cannot be corrected if an automatic function or the timer has been set (to cancel see "Electronic clock").

# Electronic clock

The electronic clock can be operated with one hand; after pressing the button, set the time with the rotary knob. Settings can be made for as long as the function display flashes (~4 seconds).

## The control panel

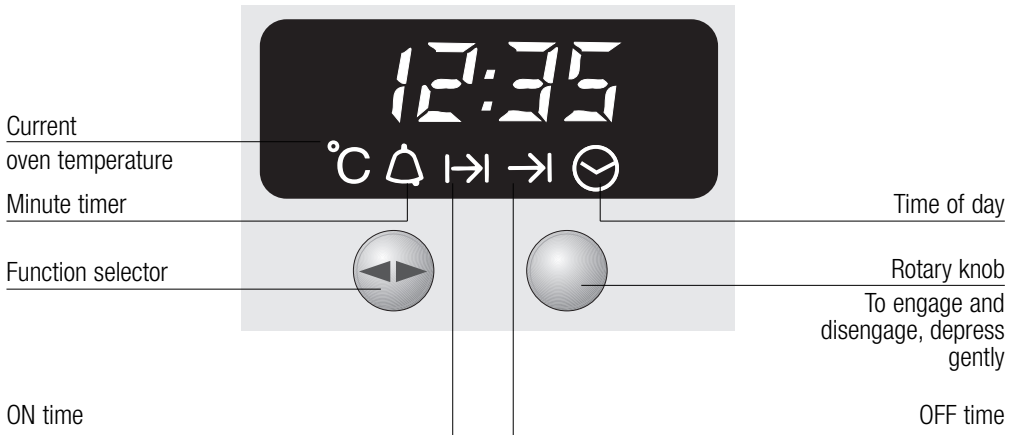

## Minute timer



1. Press the ◀▶ button and set the time (e.g. 5 minutes).  
When the timer switches on, the remaining time is displayed.
2. When the time has elapsed, a signal is emitted and the 🔔 symbol flashes. To stop the signal, press the ▶◀ button.

## Automatic timer for the main oven

### Automatic switch off

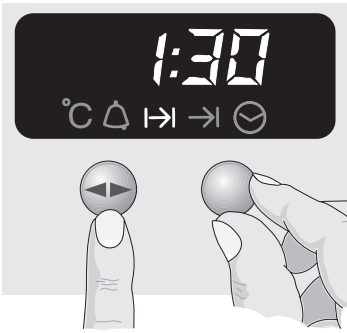

You can switch the oven on and off via the electronic clock.

If you wish to bake or roast food immediately, it is only necessary to set the ON time.

1. Select the heating system and the oven temperature.
2. Press the **↔** button until the **↔** symbol flashes and set the ON time with the rotary knob (example: 1 hour and 30 minutes). When the setting has been made, the current time is displayed after approx. 4 seconds. The **↔** symbol signals automatic mode.
3. When the time has elapsed (example: 1 hour and 30 minutes), a signal is emitted and the **→** display flashes. The oven switches off automatically. To stop the signal, press the **↔** button.
4. Switch the oven off.
5. To end automatic mode, press the **↔** button again.

### Automatic switch on and switch off



If the food is to be baked or roasted later on, both the ON time and OFF time must be set.

1. Select the heating system and the oven temperature.
2. Press the **↔** button until the **↔** symbol flashes and set the ON time with the rotary knob (example: 1 hour and 30 minutes).
3. Press the **↔** button until the **→** symbol flashes and set the OFF time with the rotary knob (example: 12:30). When the setting has been made, the current time is displayed after approx. 4 seconds. The **→** symbol signals automatic mode.



### Checking, correcting and cancelling settings

#### Note

4. The oven is automatically switched on and off at the preset times (e.g. *11:00* and *12:30*).
5. When the time has elapsed, a signal is emitted and the  $\rightarrow$  symbol flashes. To stop the signal, press the  $\blacktriangleleft$  button.
6. Switch the oven off.
7. To end automatic mode, press the  $\blacktriangleleft$  button.

1. To check your settings, press the  $\blacktriangleleft$  button until the symbol flashes.
2. If required, correct the settings with the rotary knob.
3. If you want to cancel your settings, turn the set time back to *0:00* and switch the oven off.

The automatic timer is best used with dishes which require little attention.

The minute timer and OFF time can be pre-programmed up to a max. 24 hours.

The settings can be displayed at any time by pressing the  $\blacktriangleleft$  button.

## Special functions

### Masking out the display

1. Press the  $\blacktriangleleft$  button for 7 seconds.  
After this time the display dims, the time and the display continue running in the background.
2. To switch on the display, briefly press the  $\blacktriangleleft$  button.

### Setting the time

See section "Before using your appliance for the first time".

### Dimming the display

Between 22.00 and 6.00 the display is automatically dimmed.

---

# Description of Oven Features

## Main oven

### Circotherm



A fan system located in the rear oven wall circulates the circotherm in the oven, achieving an especially effective heat transfer to the food being baked or roasted.

#### Advantages:

- Simultaneous baking and roasting possible on up to 3 levels
- low soiling of oven interior
- shorter preheating times
- low oven temperatures
- gentle defrosting

### Surface grilling

The food being prepared is exposed to heat radiation from the heating element at the top of the oven cavity.

- Particularly effective with flat, small cuts of meat, i.e., steaks, sausages, fish, vegetables and toast.

### Large area grill



#### Advantages:

- the entire grilling surface heats up
- especially useful with large amounts of food

### Small area grill



#### Advantages:

- only the centre area of the grilling surface heats up
- especially useful with small amounts of food
- energy-saving operation

### Circo-roasting



With circo-roasting, the air circulating fan and the grilling radiators are activated in alternation.

The heat generated by the grilling radiator is evenly distributed in the oven cavity.

#### Advantage:

- Particularly effective with poultry and larger cuts of meat.

## Bread-baking



Bread-baking with circotherm.

Adjustable 180–220° C.

## Dough-proving



The dough proving function provides ideal conditions inside the oven for getting yeast dough to rise.

Temperature: 35–38° C

Humidity: 75–100%

### Advantages:

- rapid and uniform increase in volume of dough
- dough does not dry out
- dough does not form a skin which means that it very easy to process and work into the required shape
- exclusion of unfavourable external influences (e.g. draughts).
- yoghurt can be made.

## AquaCleanse (oven cleaning system)



The oven cleaning function featured in your oven is intended to help you keep your oven neat and tidy. An amount of cleaning solution is vaporised automatically. The combined effects of heat and steam soften the soil deposits on the oven wall enamel and facilitate their removal. For more information on this function, see the section on "Cleaning and Care" later in this booklet. Use this function with a cold oven only.

### Advantages:

- takes the toil out of oven cleaning
- protects the enamel on interior surfaces
- constitutes an environmentally friendly cleaning method

## Rapid heat up



### Note

Can be selected for circotherm or bread-baking.

---

# Description of Oven Features

## Mini oven

### Top and bottom heat (Conventional heating system)



The food being baked or roasted is exposed to heat radiation from heating elements located at the top and bottom of the oven cavity.

Baking and roasting is possible on one slide-in level only.

#### Advantages:

- Baking of cake with moist filling, pizza, quiche.

### Surface grilling

The food being prepared is exposed to heat radiation from the heating element at the top of the oven cavity.

- Particularly effective with flat, small cuts of meat, i.e., steaks, sausages, fish, vegetables and toast.

#### Advantages:

- the entire grilling surface heats up
- especially useful with large amounts of food

### Large area grill



### Small area grill



#### Advantages:

- only the centre area of the grilling surface heats up
- especially useful with small amounts of food
- energy-saving operation

### Oven Cleaning



Oven cleaning  is a regeneration programme. If the self-cleaning panels in the oven are no longer adequately cleaned during normal day-to-day operation, they will be regenerated with this function. They will then be fully functional again.

# Switching the Oven ON and OFF

## Main oven

Example: Circotherm

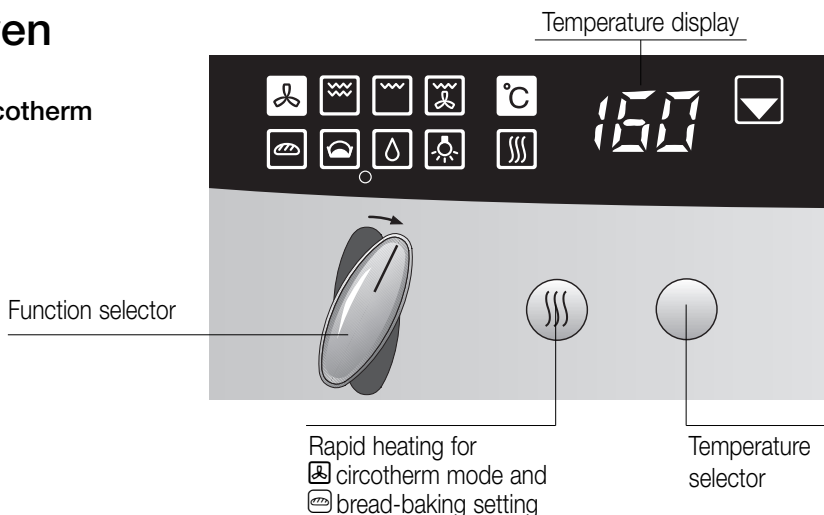

## Switching on the oven

Before you switch on your oven, decide which oven function you would like to use.

Turn the function selector until the symbol for the desired heating system illuminates.

The suggested temperature is displayed and the oven light switches on.

You can increase or reduce the suggested temperature with the temperature selector in steps of 5° C.

## Dough-proving

The dough-proving is a permanently set temperature and cannot be changed.

–  – is displayed.

## AquaCleanse

AquaCleanse is a permanently set temperature and cannot be changed.

**ECS** is displayed.

## Defrost



See the "Defrosting and cooking" section for adjusting the "defrost" setting.

## Indicator light

The indicator light for the oven temperature is lit red during the heating up phase and during reheating. The indicator light goes out when the set temperature is reached.

## Rapid heat up

### Switching on the oven

When the oven has been switched on, quick-start oven heating can be switched on with circotherm  or the bread baking setting  via the  button.

The  symbol is lit during the heating up phase. It goes out when the set temperature has been reached.



### Midterm cancelation

Press the  button, the symbol goes out and quick-start oven heating is cancelled.

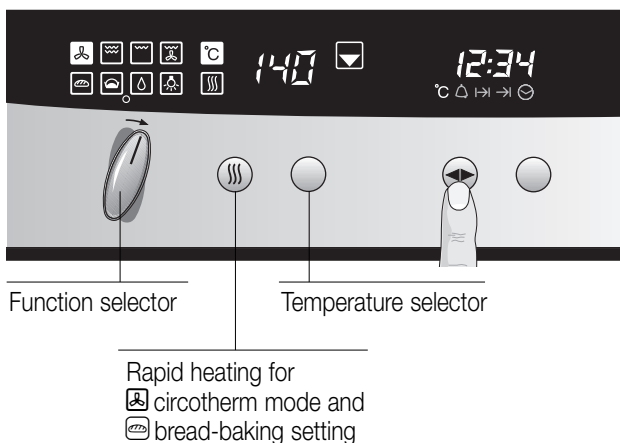
### Current oven temperature



Only during the heating up phase can the actual temperature be indicated on the temperature display for approx. 5 seconds by pressing the  button once.

You can query the actual value for the functions (except , , , defrost setting).

### Switching off the oven

Turn the function selector to the  position. All functions are deleted.





### Note





The appliance features a cooling fan which runs until the oven has cooled down.

### Oven residual heat indicators

 up ~ 120° C.  
 120° down to ~ 80° C.

## Temperature ranges of the various heating systems

System	Suggested temperature in ° C	Temperature range in ° C
	160	40–200
“Defrost” setting 	— — — —	without temperature setting
	220	50–275
	180	50–275

System	Suggested temperature in ° C	Temperature range in ° C
	170	50–250
	200	180–220
	– 0 –	fixed setting
	EE5	fixed setting

## Safety features

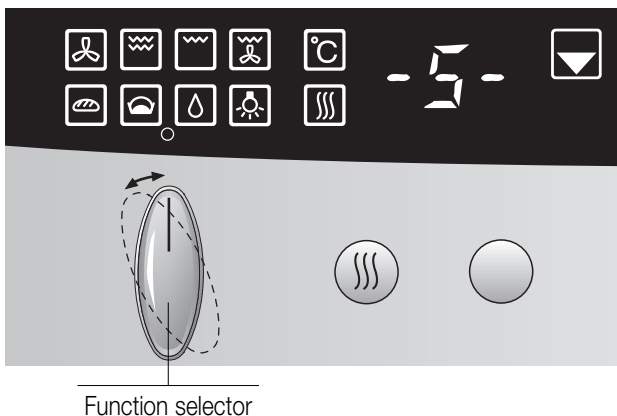

Your appliance features two locks

- oven lock
- permanent lock.

## Locking the oven

Using the function selector, switch **3 x** in rapid succession from the 0-position to the oven light  function and back again.

– 5 – is displayed.

The oven cannot be unintentionally switched on, e.g. by children.

To cancel the lock and operate the oven, switch **3x** from the 0-position to the oven light .

– 5 – is displayed.

## Permanent lock



Function selector

After using the oven, the permanent lock switches on automatically when the function selector has been in the 0-position for 30 seconds.

Switch the function selector **6x** quickly in succession from the 0-position to the oven light function  and back again.

**-5P** is displayed.

The oven cannot be switched on inadvertently or by unauthorised people (e.g. playing children).

To operate the oven, release the lock by switching **3x** from the 0-position to the oven light .

To cancel, switch again **6x** from the 0 position to the oven light .

**-5P** goes out.

## Automatic safety off function

Depending on the setting, the oven switches off automatically after 30 minutes to 30 hours and  flashes on the display.

Safety off will not function if the setting on the appliance has been changed.

**The small oven has no automatic safety cut-off.**

---

# Baking – Main oven

## Using baking tins

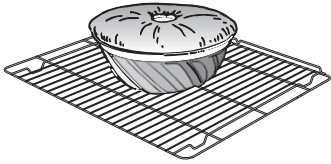

**Always place baking tins in the centre of the baking grill.**

**We recommend** dark metallic baking tins.

## Notes

Light coloured baking tins made from thin-wall materials lead to longer baking times and uneven browning of the cake.

You can influence the degree of browning by changing the temperature setting.

If a cake collapses after removing it from the oven, consider using a longer baking time, or use a slightly lower temperature setting.

## Using tinplate baking tins



Circotherm

Shelf position 1

### **If the cake bottom gets too dark:**

Check the slide-in level. Shorten the baking time, and possibly use a lower baking temperature.

### **If the cake bottom stays too light:**

Check the slide-in level. Increase the baking time, select a lower temperature, or use a dark metal baking tin.

Do not place baking forms or high cakes too close to the rear oven wall.

---

## Cooking Tips and Helpful Hints

---

<b>The bottom of a cake baked on a baking sheet stays too light</b>	Remove from the oven all baking sheets or universal baking pan currently not in use.
<b>The bottom of a cake baked in a tin stays too light</b>	Use a grill and not a baking sheet to support the cake tin during baking.
<b>The bottom of cake or cookies gets too dark</b>	Set cake or cookies into a higher set of slide-in levels.
<b>The cake gets too dry</b>	Select a slightly higher oven temperature, and shorter baking time.
<b>The cake is too moist on the inside</b>	Choose a slightly lower baking temperature. <b>Note:</b> Higher temperatures do not shorten baking times (done on the outside, raw on the inside). Choose a slightly longer baking time, allow the dough to rise slightly longer. Add less liquid to the dough.
<b>When baked with circotherm circulation, cake baked in round or square tins gets too dark at the rear</b>	Avoid blocking the air vents at the rear wall of the oven cavity with the cake tins.
<b>Very moist cake dough (e.g. fruit cake) causes a lot of steam to generate in the oven that condenses on the oven door.</b>	You can let the steam escape from the oven and thereby reduce the forming of water droplets by briefly and carefully opening the oven door (once or twice, in case of longer baking times more often).
<b>Very uneven browning when using circotherm circulation</b>	Check the slide-in level.
<b>Cake collapses when taken out of the oven</b>	Use less liquid.
<b>To save energy</b>	Preheat only if expressly required by the recipe. Dark baking tins have a higher degree of heat absorption. <b>Residual heat:</b> In the case of longer baking times, you can switch off the oven 5-10 minutes before the full baking time has elapsed.

---

---

# Roasting – Main oven

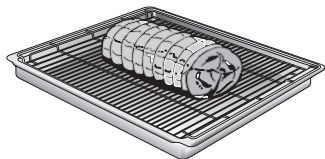

## Roasting in an uncovered pot

**Place the grill into the universal baking pan and slide them together into the same slide-in level.**

Meat can be roasted in the oven in a particularly economical fashion if the weight of the cut exceeds 750 grams.

Rinse the universal baking pan and/or the roaster with water, and place the meat into it.

With fat meat and poultry, pour 125 to 250 ml of water (to suit the size and kind of roast) into the universal pan. At your discretion, baste lean meat with fat, or cover it with bacon strips.

The roast drippings collecting in the universal pan make a tasty gravy. Dissolve the drippings with hot water, bring to a boil, thicken with corn starch, season to taste and, if required, pass it through a strainer.

No preheating is required. Save energy by putting the roast into the oven while it is still cold.

## Roasting in a covered pot

Place the meat into the roasting pot (or Dutch oven), cover it with a matching lid, and place it on the grill in the oven. We recommend that beef roast be prepared in a covered roasting pot.

## Roasting on the roasting sheet

(Optional accessory available from your dealer).

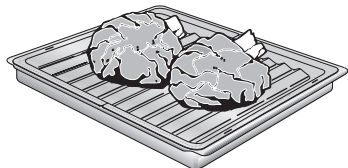

Place the roasting sheet into the universal pan. The roasting sheet prevents soiling of the oven.

Grease and juice drippings from the roast are collected in the universal pan.

## Tips

### **Big, high roasts, goose, turkey, duck**

= Long roasting times, low temperatures

### **Medium sized, low roasts**

= Medium roasting times, medium temperatures

### **Small, flat roasts**

= Short roasting times, high temperatures

Roasting time per cm of meat height without bones  
app. 13-15 minutes

Roasting time per cm of meat height with bones  
app. 15-18 minutes

**We recommend** using the lower of the stated temperatures first.

In general, the lower temperature ensures a more even browning.

**We recommend** turning the roast after half or two thirds of the roasting time have elapsed.

For roasting, use only cookware with oven-proof handles.

Prepare large roast directly in the universal pan, without using the grill.

Smaller cuts of roast can be roasted on aluminium foil. To do so, bend the edges of the foil upward, as if to form a dish, and place it on the grill.

After the end of the selected roasting time and with the oven switched OFF, leave the roast in the closed oven for approx. 10 minutes.

---

**The roast is not done on the inside**

Use a lower roasting temperature.

**Note:** Higher temperatures do not shorten roasting times (done on the outside, raw on the inside).

Choose slightly longer roasting times.

---

**Very moist roasts (e.g. roasts prepared with water) cause a lot of steam to generate in the oven that condenses on the oven door.**

You can let the steam escape from the oven and thereby reduce the forming of water droplets by briefly and carefully opening the oven door (once or twice, in case of longer roasting times more often).

---

# Grilling – Main oven

 Exercise **CAUTION** when grilling.  
**Always keep children at a safe distance.**

## Notes on grilling

Always close the oven door when grilling.

The grilling temperatures are variable.

Always use the grill and the universal pan.

Always place food to be grilled in the centre of the wire grill.

If the grill element (heating element) switches OFF automatically, the overheating protection was activated.

The radiator will be reactivated after a short period of time.

**Place the grill into the universal baking pan and slide them together into the same slide-in level.**

---

## Circo-roasting

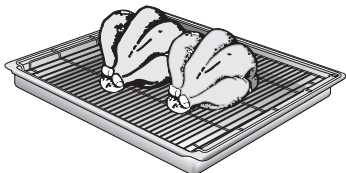

Use this method for particularly crispy poultry or roast (e.g., pork roast with crackling).

Use the grill and universal pan together. Turn large roasts after about half of the total grilling time has elapsed.

To prevent breakage after removing them from the oven, place glass utensils on a dry kitchen towel instead of cold or wet surfaces.

Dependent on the type of food being prepared, combination hot-air and surface grilling can cause an increased degree of oven soiling. Therefore, to prevent burning-in of the soil, thorough cleaning of the oven is recommended after each use.

Whole poultry should be turned after approx. two-thirds of the cooking time has elapsed.

With duck and goose, pierce the skin under the wings to allow excess fat to drain off.

After the end of the selected roasting time and with the oven switched OFF, leave the roast in the closed oven for approx. 10 minutes.

---

## Surface grilling

Large area grill 

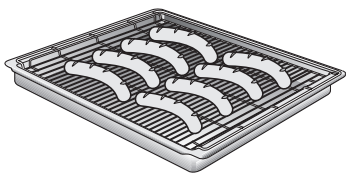

Used for smaller dishes having little height/thickness.

Always use the grill and universal pan together.

Turn the food after approx. two-thirds of the grilling time has elapsed.

At your discretion, lightly baste the grill and the food with oil.

Small area grill 

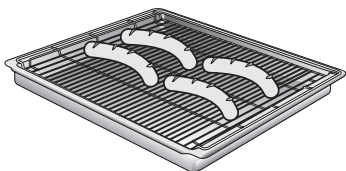

# Switching the Oven ON and OFF

## Mini oven

### Function selector

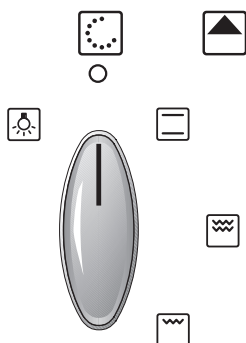

Before switching on your oven, you should decide which heating system you wish to use.

### Switching the oven ON:

1. Use the function selector to determine the desired system.
2. Set the temperature control knob to the desired temperature.

The selected temperature will be controlled automatically.

The oven temperature control lamp illuminates when the oven is first switched on, and extinguishes when the required temperature has been reached.

### Temperature selector

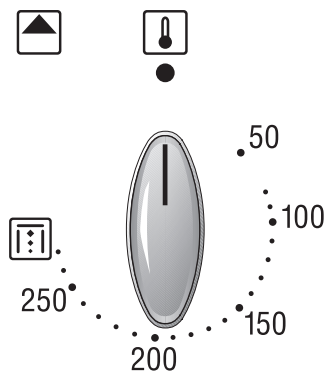

### Switching the oven OFF:

To switch the oven OFF, turn both the temperature selector and functions selector to the »0« position.

### Notes:

The appliance features a cooling fan which runs until the oven has cooled down.

---

# Roasting – Mini oven

## Roasting with conventional heat

Follow the steps above. With fatty meat 125 – 250 ml (4 – 8fl oz) of water can be poured into the roasting pan.

Baste the meat if desired.

Place in a cold oven to save energy or pre-heat if desired.

## Casseroling or pot-roasting in a covered dish

Some meats should be prepared in liquid in a covered casserole. This type of cooking is suitable for less tender cuts of meat.

Place the casserole on the wire shelf at a suitable shelf position.

## Cooking tips

Only use ovenproof cookware.

Extra large turkeys and joints can be placed directly in the roasting pan and not on the wire shelf.

Cover large turkeys with foil during cooking. Remove foil during the last hour.

---

# Grilling– Mini oven

 Exercise **CAUTION** when grilling.  
Always keep children at a safe distance.

## Notes on grilling

Always close the oven door when grilling.  
The grilling temperatures are variable.  
Always use the grill and the universal pan.  
Always place food to be grilled in the centre of the wire grill.

If the grill element (heating element) switches OFF automatically, the overheating protection was activated.  
The radiator will be reactivated after a short period of time.

**Place the grill into the universal baking pan and slide them together into the same slide-in level.**

---

## Surface grilling

Large area grill 

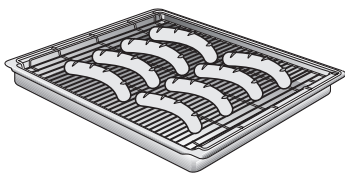

Used for smaller dishes having little height/thickness.

Always use the grill and universal pan together.

Turn the food after approx. two-thirds of the grilling time has elapsed.

At your discretion, lightly baste the grill and the food with oil.

Small area grill 

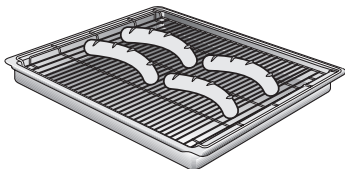

---

# Defrosting and cooking – Main oven

---

## Defrosting and cooking using the Circotherm

Important heating system information

For defrosting and cooking of frozen or deep-frozen foods, use only the circotherm.

**With all deep-frozen foods, follow the food processing company's instructions on the package.**

As a rule, **defrosted frozen or deep-frozen foods** (especially meats) require less cooking time than fresh products, since freezing has a pre-cooking effect.

If **frozen meat** is placed in the oven, the defrosting time must be added to the required cooking time.

Always defrost **deep-frozen poultry** before cooking because the giblets must be removed.

For cooking **deep-frozen fish**, use the same temperatures as for fresh fish.

**Deep-frozen ready-to-eat meals** in aluminium dishes may be placed into the oven several at a time.

**Frozen vegetables** (i.e., when cooking complete meals) should be cooked in a covered pot together with the roast. Use only approximately half of the liquid specified in the recipe. Use fat only for adding flavour.

Slide-in levels

**With 1 baking sheet:** Slide-in level **1**

**With 2 baking sheets:** Slide-in levels **1 + 3**.

**All stated times** are approximate guidelines that vary with the shape and volume of deep-frozen products.

## Defrosting

**Raw deep-frozen products or foods from a freezer** always defrost at 50° C.

Higher defrosting temperatures may cause the food to dry out.

Defrost **deep-frozen meals packed in aluminium foil or closed aluminium containers** at a setting of 130 – 140° C.

Place frozen meals **packed in plastic bags or plastic containers** in a pot filled with water. Cover the pot and defrost at 130 – 140° C.

**Attention:** Pot handles must be oven-proof.

Defrost and warm up **deep-frozen baked goods** at 100 – 140° C. Brush bread, rolls or yeast pastry lightly with water to make the crust more appealing.

Defrost **dry deep-frozen yeast cakes** at 160 – 170° C for 20 – 30 minutes.

Defrost **moist deep-frozen yeast cakes** (with fruit topping) at 160 – 170° C for 30 – 50 minutes after wrapping in aluminium foil to prevent cake from drying out.

Defrost and toast **deep-frozen toast** (with topping) at 160 – 170° C for about 20 minutes.

**Frozen pizza:**

Please follow the manufacturers' instructions.

## Defrost Main oven

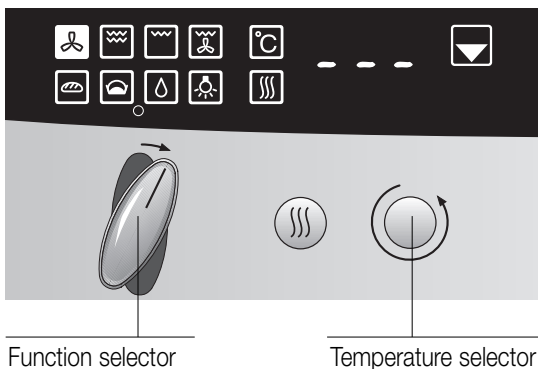

Recommended for delicate bakeware only (i.e., whipped-cream gateaus).

1. Turn the function selector to position .
2. Reduce the oven temperature with the temperature selector until --- is displayed.

The fan at the oven wall runs without heat being generated.

Depending on size and type of bakeware, defrost for 25 – 45 minutes. After this time, remove the pastry from the oven.

Let stand at room temperature for 30 – 40 minutes.

With smaller amounts (pastries) the defrosting time is reduced to 15 – 20 minutes and the subsequent standing time to 10 – 15 minutes.

## Using the dough-proving Main oven

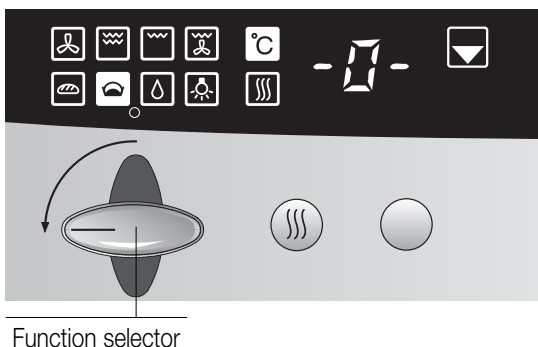







### Warning

Do not use the dough-proving setting until **the oven has cooled down completely** (room temperature).

Use normal tap water only, **not distilled water**.

## Switching ON

1. Carefully pour 50 millilitres of water ( $\frac{1}{4}$  glass) onto the floor of the oven cavity.
2. Place the bowl containing the dough onto the middle of a wire shelf inserted at level **1**.  
 Do not cover the dough.
3. Close the oven door.
4. Turn the function selector to position .  
The  indicator light comes on and -  - is shown on the display.  
The proving process is controlled automatically.

 If -  - flashes when the oven is switched on, the oven is too hot.

Switch the oven off.

Wait until the oven has cooled down to room temperature.

Restart the dough-proving setting.

Yeast dough	Amount of flour	Shelf level	Proving period
Cakes up to	500 g.	1	20–25 min.
Cakes up to	500–750 g.	1	25–30 min.
Dough for plaited loaf	500 g.	1	30–35 min.
Dough for plaited loaf	750 g.	1	30–40 min.
Dough for normal loaf	1000 g.	1	35–60 min.
Jogurt	1 litre milk	1	6 hours

### Important

When making yoghurt, do not put any water in the oven.

The details given in the table above are average values. They can vary according to the type and amount of dough, as well as the condition of the ingredients, e.g. age and quality of the yeast.

Before you start baking, remove the water left inside the oven. If any traces of lime are left behind, they can be dissolved with a little vinegar and wiped off using clear water.

Never pour cold water into the oven while it is still hot.

### Switching off

Turn the function selector to the  position.

---

# Cleaning and Care

---

## Important cleaning basics

For cleaning, do not use abrasives, no corrosive cleaners, and no sharp objects.

Do not scratch off burnt-in food residues, but soak them off with a moist cloth and dishwashing detergent.

Special cleaners, such as oven cleaning spray, must not be used on aluminium or plastic parts.

## Stainless steel front

When using commercially available stainless steel cleaning agents, the lettering may become damaged.

Do not use scouring sponges.

Use commercially available detergents applied to a soft, moistened cloth or a chamois.

## Enamel and glass

Use hot detergent suds for cleaning.

Remove the oven door before cleaning the enamel surface.

## Oven door pane

The temperature of the pane inside the oven door is reduced by a heat-reflecting coating.

The reduced temperature ensures that visibility through the oven door window is not impaired.

When the oven door is open, this coating may have a bright appearance. This is quite normal and does not indicate a quality defect.

## Oven interior

Clean the oven after each use, especially after roasting or grilling.

Food remnants burn in when the oven is reheated. The baked in remnants are very difficult to remove once burnt in.

You can reduce the degree of soiling by frequent cleaning using the cooking system.

 Do not clean the warm oven with any of the cleaning products specifically designed for this purpose.

When baking very moist cake, use the universal baking pan.

For roasting, use the appropriate utensils (Dutch oven).

Clean the oven before soiling becomes too heavy. Wash out the oven cavity with hot detergent suds.

Leave the door open until the interior has dried.

---

## Catalytic oven surfaces

### Cleaning the catalytic surfaces of the oven

The rear wall of the oven is coated with self-cleaning enamel. The surface cleans itself while the oven is in operation. Large splashes sometimes only disappear after the oven has been used several times.

Never use oven cleaner on the back wall of the oven.

Should the enamel become slightly stained, this will not affect its self-cleaning properties.

### Cleaning the oven floor, the oven ceiling and the side walls

Use hot soapy water or a vinegar solution.

It is best to use oven cleaner if the oven is very dirty. Only use oven cleaner in a cold oven.

Note:

Enamel is baked on at very high temperatures.

This can cause some slight colour variation. This is normal and does not affect the function. Do not use coarse scouring pads or strong cleaning agents to remove such discolorations.

The edges of thin trays cannot be completely enamelled. As a result, these edges can be rough. Anti-corrosion protection is guaranteed.

# Main oven

## AquaCleanse

The oven cleaning function featured in your oven is intended to help you keep your oven neat and tidy. An amount of cleaning solution is vaporised automatically. The combined effects of heat and steam soften the soil deposits on the oven wall enamel and facilitate their removal.

### Caution:

Use this function only after the **oven has completely cooled** (room temperature).

Use normal water only, and **no distilled water**.

### Activate oven cleaning:

1. Remove the baking sheet and the universal baking pan from the oven. The baking grill may remain in the oven.
2. Pour approx. 400 ml of water mixed with a little dishwashing detergent into the floor pan of the oven cavity.



In the case of heavy soil build-up, you may wish to allow the cleaning solution to soak in for a while before you activate the cleaning function.

3. Close the oven door.

### Warning:

The cleaning system can only be activated **when the oven has cooled down completely**.

4. Turn the function selector to the  position.

The  indicator light and the  indicator light for oven temperature illuminate. **ECS** is displayed. If **ECS** flashes, the oven has not cooled down completely.

After the initial heating time (approx. 4 minutes) the oven temperature control lamp extinguishes. After a further 17 minutes the program cycle is completed. A buzzer sounds.

### Switching the oven OFF:

Turn the function selector to the **0** position.

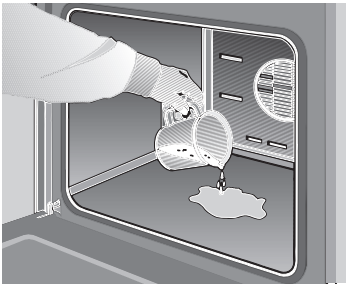

## After deactivating the oven cleaning function

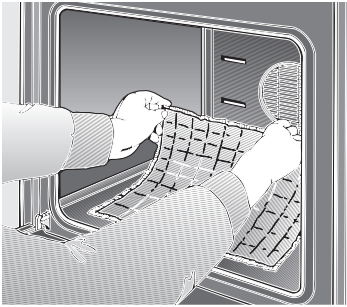

### Cleaning tips:

Never leave the residual water in the oven for any length of time, e.g. overnight.

1. Open the oven door and pick up the remaining water with a large absorbent sponge cloth.
2. Using the detergent-soaked sponge cloth, a soft brush or a plastic pot scrubber, wipe of the oven interior.

Stubborn soil remnants can be removed with a cleaning scraper for glass-ceramic.

**Caution:** Use the scraper carefully, and do not apply the tool at too flat an angle, because the enamel could be scratched!

3. Calciferous deposits may be removed with a cloth soaked in vinegar.
4. Wipe clean with clear water and dry with a soft cloth (do not forget to wipe under the oven door seal).

### Cleaning tips:

If the oven is heavily soiled, the procedure may be repeated after the oven has cooled.

If the oven is heavily soiled with grease, e.g. after roasting or grilling, we would recommend rubbing any stubborn dirt with detergent before activating the oven cleaning function.

After cleaning, leave the oven door in its slanted detent position, i.e., at a 30-degree angle, to allow the interior enamel surfaces to dry thoroughly.

1. Place the oven door into the slanted detent position, at an angle of approximately 30 degrees.
2. Turn the function selector to position .
3. Reduce the oven temperature with the temperature selector until **50° C** is displayed.
4. Duration: approximately 5 minutes.
5. Then switch the oven off.

## Rapid drying

---

# Mini oven

## Oven Cleaning

### Automatic oven cleaning



Oven cleaning  is a regeneration programme. If the self-cleaning panels in the oven are no longer adequately cleaned during normal day-to-day operation, they will be regenerated with this function. They will then be fully functional again.

### **Take the accessories and utensils out of the oven.**

Before switching on automatic oven cleaning, thoroughly clean the areas of the oven that do not have self-cleaning panels, e.g. enamelled areas such as the oven floor, inner door. This will prevent residue from burning in.

** The oven becomes very hot during automatic oven cleaning – always keep children away.**

### Setting procedure

1. Rotate the function selector to bottom/top heating  and the temperature selector to Oven Cleaning  (270° C).  
Heat up the oven for 1 hour.

### Switching off oven cleaning

2. Rotate the temperature selector and the function selector to 0.  
The oven is cooled by the fan which continues running.

### When the oven has cooled down

Remove the grease film from the parts which are not self-cleaning with a damp cloth.

Wipe the salt residue off the self-cleaning parts with a damp cloth.

Replacement side, roof and rear panels are available from customer service.

**Note:** exchange of roof and rear panels should only be carried out by an approved service engineer.

## Oven door

**Note:** To make the manual cleaning steps following the automatic oven cleaning function more convenient, the appliance features the following options.

### Removing the oven door

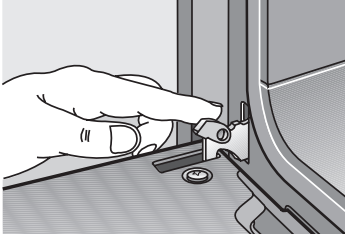

1. Fully open the oven door.
2. Move the catch levers on the right and left-hand sides to the fully open position.
3. Placing the door at an upward angle toward you, grasp the door with both hands and lift it out of the hinges toward you.

### Hanging the oven door



1. Set both hinges into their respective receptacles on the left and right, and swing the oven door downward.
2. Close the catch levers on the left and right.
3. Close the oven door.

## Inset rack

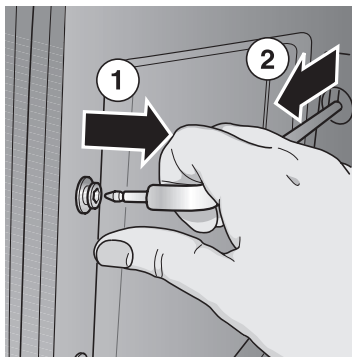

### Removing

1. Pull the inset rack out of its bearing bush.
2. Remove the inset rack.

Clean the rack using washing-up liquid and pan scrapers or brushes.

---

## Service and Repair Information

In the event of problems or repairs that you cannot solve or perform yourself, our customer service will be happy to help. Check the customer service directory for a customer service facility in your area.

**Caution:** Calling the customer service because of an operator error can be very costly!

### E No and FD No

You can find this information on the appliance's nameplate. The nameplate is located on the appliance, behind the oven door, on the left bottom edge of the oven.

In the event of a customer service request, please have the following information handy:

<b>E-Number</b>	<b>FD</b>
-----------------	-----------

## Replacing the oven light

### Main oven

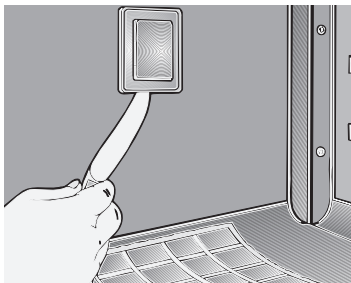

**Caution: Unplug the appliance or remove the fuse! By actuating the miniature circuit-breaker or by unscrewing the fuses in the fuse box in your house.**

1. To prevent damage, place a cloth into the cold oven.
2. Remove the glass cover by inserting a knife or similar object between the glass and the frame.
3. Replacing the lamp:
  - Type: Incandescent bulb E 14, 230 - 240 V, 25 W, heat resistant to 300° C.
  - You can obtain this lamp from our spares department.

### Mini oven

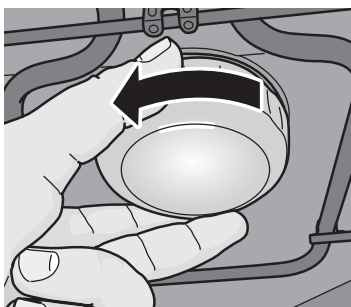

1. To prevent damage, place a towel into the cold oven.
2. Unscrew the lamp cover by turning it counter-clockwise.
3. Replace the lamp.
  - Type: Incandescent bulb E 14, 220 – 240 V, 40 W, heat-resistant to 300° C
  - You may obtain this bulb from your customer service or from your appliance dealer.

## Replacing the oven door seat

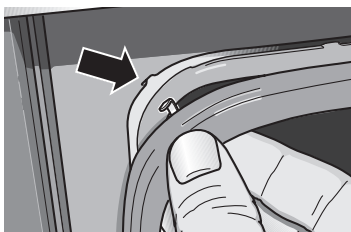

Remove the defective oven door seal by simply unhooking it. You may obtain the new oven door seal from your customer service.

---

# Trouble-shooting Guide

Calling the customer service is not always really necessary. In some cases, you can remedy the situation yourself. The following table may contain some helpful tips.

## Important general safety guidelines:

Service or repair work on the electronic components may only be performed by a qualified expert. Without exception, prior to starting such repairs, the appliance must be disconnected from the mains. This may be accomplished by tripping the automatic fuse or by removing the fuse from the fuse box that controls your flat or apartment.

Problem	Possible cause	Remedy
. . . if there is a general failure of all electrical functions, i.e., the control lamps have suddenly ceased to function.	Defective fuse	Check the fuse in the fuse box, and replace if required.
. . . if liquids or thin viscous dough are distributed at a visibly uneven thickness?	The appliance has not been placed or installed plumb-and-level.	Level the appliance using the leveling feet, or check the installation.
. . . if the oven suddenly stop functioning?	The electronic clock is set to an automatic timing cycle.	Set electronic clock to operation without automatic timer: <b>1.</b> Press the ◀▶ button. <b>2.</b> Reset ON time → to 0:00.
. . . if the oven suddenly stop functioning and the electronic clock flashes 0:00?	The power supply was briefly interrupted.	Reset the time of day.
. . . if electronically control functions fail?	Energy pulses (e.g. lightning flash).	Reset the relevant functions.
. . . if the oven cleaning control lamp fails to illuminate after the function has been activated?	Temperature inside oven cavity is still too high, i.e. after prolonged use of the hotplates.  Defective control lamp.	Prior to using the oven cleaning function, the oven must be allowed to cool completely.  Replacement only by an authorised expert.

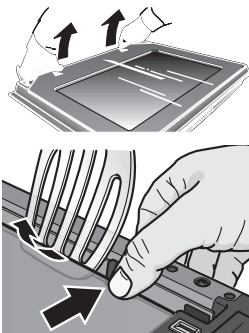
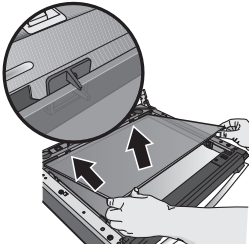
Problem	Possible cause	Remedy
. . . if smoke is generated during roasting or grilling?	Roasting temperature to high.  Grill or universal pan slid in incorrectly.	Place grill into universal pan and insert together in slide-in level.
. . . if enamelled slide-in parts show mat bright stains?	Normal occurrence due to dripping meat juices.	Not available.
. . . if the glass pane or window of the oven door become clouded?	Normal occurrence, due to existing temperature difference.	Switch on the oven for app. 5 minutes at 100° C.
. . . if the oven shows increasing condensation water?	Normal occurrence, e.g. in the case of cakes with very moist topping (fruit) or roasts.	Briefly open the oven door occasionally during baking or roasting, wipe up the condensation water after operation.
. . . if the panes of the oven door are dirty on the inside after some time of use?	Normal soiling. 	<b>Remove the oven door</b> and place it facing down on a clean and soft surface.  Grip the <b>door glass</b> next to the hinges, pull the upward and remove it.  Press in the retaining clip with your thumb on one side and disengage the <b>inner door glass</b> e.g. with the spatula, then repeat on the other side.
		<b>Installation after cleaning:</b> Insert <b>inner door glass</b> into the holder. First engage the right side and then the other side.
		Hang <b>door glass</b> and press down next to the hinges until it clicks into place.

---

# Assembly Instructions

For the installer  
and kitchen expert!

---

## Important installation notes

Properly dispose of **packaging materials**.

Do not use **oven door handle** for transporting or handling the unit during installation.

**WARNING:** Connection and first start of the appliance may only be performed by an authorised specialist.

Connection must be made using an H05RR-F 3 G 1,5<sup>2</sup> mains connection cable.

### **Rated consumption, rated voltage and type no. of the appliance:**

See appliance nameplate behind the oven door to the left beneath the side edge of the oven.

### **The unit's nameplate is located at on the sidewall of the unit.**

**Electrical safety** of the appliance can be ensured only if the equipment earth in the building installation has been installed according to regulations.

On the installation side a separating device shall be provided. Any switch with a contact gap exceeding 3 mm may be considered a separating device. Other examples are LS switches, fuses and contactors.

**In the case of repairs** interrupt all power connections to the unit.

The properly installed appliance must be covered on all sides in such a fashion that not even components with rough insulation are exposed to the touch.

The cover must be removable with tools only.

The **connection diagramm** is located on the rear panel of the appliance.

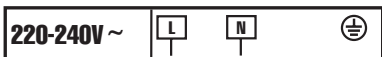

## Installation of the built-in oven

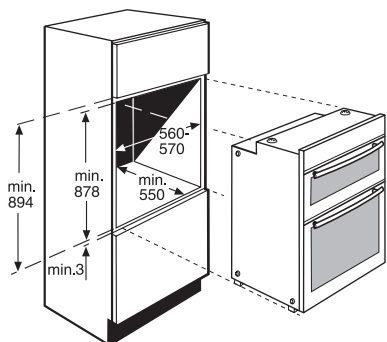
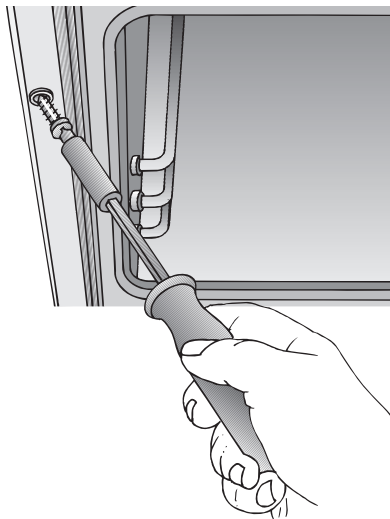

Push the oven into the cabinet aperture and align the unit until it is in a **level position**.

Open the oven door and, using one screw on each side, fasten the built-in oven to the side strips of the conversion cabinet.

The two screws (supplied with the built-in oven) must be started slightly outward.

Verify that the built-in oven is positioned securely and in a **level position**, and that the required installation dimensions have been maintained.

**In units featuring automatic oven cleaning, after filling 0,4 l of cleaning solution into the recess in the oven floor, the liquid must not spill toward the front.**

### Furniture requirements

Oven housings from virtually all lines of kitchen furniture are suitable for installing the built-in oven. However, the veneers or plastic laminates on the conversion cabinets must be applied with heat-resistant adhesive (90 C).

If plastic laminates or cement are not sufficiently heat-resistant, warping, bubbling or detachment of the finish may result.