



Dear customer,

congratulations on the purchase of your new Neff oven. We would like to thank you for your confidence in us and we hope that you will have many years of enjoyment and cooking pleasure with your new appliance.

To be able to take full advantage of all the technical features of your cooker, please read these instructions for use.

The detailed table of contents will guide you quickly to all the important information:

- You will be informed of important safety information.
- You will then be familiarised with the individual parts of your new oven.
- Step by step guide on how to select particular settings.
- The tables list the settings and shelf positions for a selection of typical recipes, all of which are tested in our cookery centre.
- In the unlikely event of a malfunction, this is where you will find information on how to rectify minor faults yourself.

Have fun cooking.

Distributed in Australia by SAMPFORD IXL
telephone 1300 727 421

Instructions for use

B15E44.0AU

en

9000 416 157

Table of contents

Safety information	5
Before installation	5
Information for your safety	5
Causes of damage	7
Energy and environment tips	8
Saving energy	8
Environmentally friendly disposal	8
Your new appliance	9
Control panel	9
Operating modes	10
Shelf positions	11
Accessories	12
Before using the appliance for the first time ...	13
Setting the time	13
Cleaning the appliance	14
Using the appliance	14
Switching on the appliance	15
Switching off the appliance	17
Changing the basic settings	17
Automatic safety switch off	18
Electronic clock	18
Clock display	19
Timer	20
Cooking time	20
End of operation	21
Preselection mode	22

Table of contents

Setting the time	23
Rapid heating	23
Checking, correcting or deleting settings	24
Childproof lock	24
Locking	24
Permanent lock	25
Baking	27
Baking on one level	27
Baking on two or more levels	28
Baking table	29
Baking table for pre-prepared products	31
Tips and tricks	33
Roasting and braising	34
Roasting	34
Braising	35
Tables for roasting and braising	36
Tips and tricks	38
Grilling	39
Circo-roasting	40
Radiant grilling	40
Grilling table	41
Low-temperature cooking	42
Using Low-temperature cooking	43
Table for Low-temperature cooking	44
Tips and tricks	45

Table of contents

Defrosting	46
Defrosting with Circotherm hot air	46
Defrost setting	47
Yoghurt	47
Cleaning and care	48
Cleaning the appliance exterior	49
Cleaning the cooking compartment	49
Self-cleaning surface	50
EasyClean	51
Removing and fitting the appliance door	53
Cleaning the door panels	55
Cleaning the cooking compartment ceiling	57
Cleaning the hook-in racks	57
Cleaning the telescopic shelves	58
Faults and repairs	59
Changing the cooking compartment bulb	60
Replacing the door seal	61
After-sales service	62
Test dishes	62

Safety information

Read this instruction manual carefully. Please keep the instruction and installation manuals in a safe place. Please pass on these manuals to the new owner if you sell the appliance.

Before installation

Transport damage

Check the appliance for damage after unpacking it. Do not connect the appliance if it has been damaged in transport.

Electrical connection

Only allow a licensed professional to connect the appliance. Damage caused by incorrect connection is not covered under warranty.

Information for your safety

This appliance is intended for domestic use only. This appliance must only be used for food preparation.

This appliance is not intended for use by persons (including children) with reduced physical, sensory or mental capabilities, or lack of experience and knowledge, unless they have been given supervision or instruction concerning use of the appliance by a person responsible for their safety. Children should be supervised to ensure that they do not play with the appliance.

Hot cooking compartment

There is a risk of burns.

Never touch the interior surfaces of the cooking compartment or the heating elements. Open the appliance door carefully. Hot steam may escape. Small children must be kept at a safe distance from the appliance.

During use the appliance becomes hot. Care should be taken to avoid touching heating elements inside the oven.

Accessible parts may become hot during use. To avoid burns young children should be kept away.

There is a risk of fire.

Never store combustible items in the cooking compartment.

Never open the appliance door if there is smoke inside. Switch off the appliance. Pull out the mains plug or switch off the appliance by the fuse in the fuse box.

There is a risk of short-circuiting.

Never trap connecting cables of electrical appliances in the hot appliance door. The cable insulation could melt.

There is a risk of scalding

Never pour water into the hot cooking compartment. This will cause hot steam.

There is a risk of burns.

Never prepare food containing large quantities of drinks with a high alcohol content. Alcoholic vapours can catch fire in the cooking compartment. Only use small quantities of drinks with a high alcohol content and open the appliance door carefully.

Hot accessories and ovenware

There is a risk of burns.

Never remove ovenware and accessories from the cooking compartment without an oven cloth or oven gloves.

Incorrect repairs

There is a risk of electric shock.

Incorrect repairs are dangerous. Repairs may only be carried out by one of authorised persons.

If the appliance is defective, pull out the mains plug or switch off the appliance by the fuse in the fuse box.

Call the after-sales service.

Causes of damage

Accessories, foil, greaseproof paper or ovenware on the cooking compartment floor

Do not place accessories on the cooking compartment floor. Do not cover the cooking compartment floor with any sort of foil or greaseproof paper. Do not place ovenware on the cooking compartment floor if a temperature of over 50 °C is set.

This will cause heat accumulation. The baking and roasting times will no longer be correct and the enamel will be damaged.

Water in the hot cooking compartment

Never pour water into the hot cooking compartment. This will cause steam. The temperature change can cause damage to the enamel.

Moist food

Do not store moist food in the closed cooking compartment for long periods. This will damage the enamel.

Fruit juice

When baking very moist fruit flan, do not put too much on the baking tray. Fruit juice dripping from the baking tray leaves stains that cannot be removed. If possible, use the deeper universal pan.

Cooling with the oven door open

Only leave the cooking compartment to cool with the door closed. Even if you only leave the oven door open slightly, the fronts of adjacent units may become damaged over time.

Very dirty oven seal

If the oven seal is very dirty, the oven door will no longer close properly when the oven is in use. The fronts of adjacent units could be damaged. Always keep the oven seal clean.

Oven door as a seat or storage space

Do not stand or sit on the open oven door. Do not place ovenware or accessories on the oven door.

Transporting the appliance

Do not carry or hold the appliance by the door handle. The door handle cannot support the weight of the appliance and could break.

Energy and environment tips

Here you can find tips on how to save energy when baking and roasting and how to dispose of your appliance properly.

Saving energy

Only preheat the oven if this is specified in the recipe or in the operating instruction tables.

Use dark, black lacquered or enamelled baking tins. They absorb the heat particularly well.

Open the appliance door as little as possible during cooking, baking or roasting.

It is best to bake several cakes one after the other. The cooking compartment is still warm. This may reduce the baking time for the second cake.

For longer cooking times, you can switch the oven off 10 minutes before the end of the cooking time and use the residual heat to finish cooking.

Environmentally-friendly disposal



Dispose of packaging in an environmentally-friendly manner.

This appliance is labelled in accordance with European Directive 2002/96/EC on Waste Electrical and Electronic Equipment - WEEE.

The directive gives a framework for the collection and recycling of old appliances, which is valid across the EU.

Your new appliance

This section provides information on

- the control panel
- the operating modes
- the shelf positions
- the accessories

Control panel

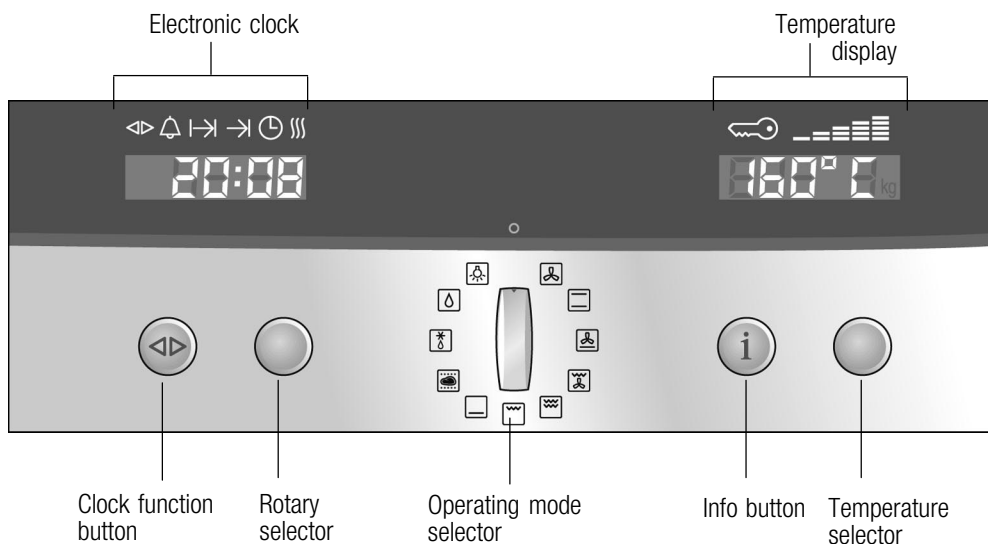

Control element	Use
Clock function button	Selects the desired clock function or rapid heating (see section: Electronic clock)
Rotary selector	Makes settings within a clock function or activates rapid heating (see section: Electronic clock)
Operating mode selector	Selects the desired operating mode (see section: Switching on the appliance)









Control element	Use
Info button	When the appliance is switched on: displays the current temperature during the heating up phase (see section: Switching on the appliance) When the appliance is switched off: calls up the basic settings menu (see section: Changing the basic settings)
Temperature selector	When the appliance is switched on: sets the temperature (see section: Switching on the appliance) When the appliance is switched off: changes the settings in the basic settings menu (see section: Changing the basic settings)



Pop-out control knobs

The rotary, temperature and operating mode selectors can all be popped out. Simply push the appropriate control knob to pop it in or out.

Operating modes

Here is an overview of the operating modes of your appliance.

Mode of operation	Application
 Circotherm® hot air	for baking and roasting on one or more levels
 Top/bottom heating	for baking and roasting on one level. It is ideally suited for cakes with moist toppings (e.g. cheesecake).
 Circotherm intensive	for deep-frozen ready-made products and dishes which require a lot of heat from underneath. (see section: Baking)
 Circo-roasting	for poultry and larger pieces of meat
 Full-surface grill	for large amounts of flat, small items for grilling (e.g. steaks, sausages)
 Centre area grill	for small amounts of flat, small items for grilling (e.g. steaks, bread)
 Bottom heating	for food and baked goods which should form a crust or which need more browning on the underside Only activate bottom heating for a short while at the end of the baking time.
 Low-temperature cooking	for tender pieces of meat, that are to be cooked medium/rare or medium
 Defrost setting	for gentle defrosting of pieces of meat, bread and delicate desserts (e.g. cream gateaux)

Mode of operation	Application
 Easy Clean®	makes cleaning the cooking compartment easier
 Cooking compartment lighting	provides assistance when maintaining and cleaning the cooking compartment

Shelf positions

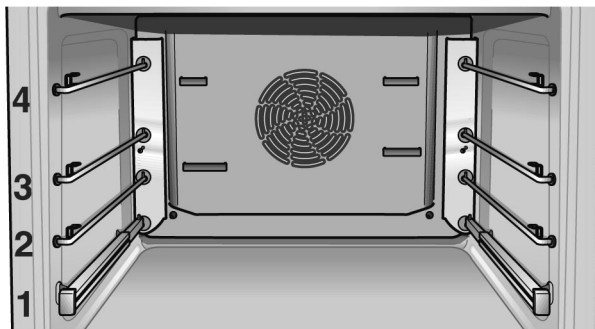

The cooking compartment has four shelf positions. The shelf positions are numbered from the bottom to the top.

The individual shelf units can be inserted into your preferred shelf positions. This single insertion system allows flexible and quick handling when changing shelves.



The telescopic shelves become hot when the appliance is in use. Take special care not to get burnt when they are pulled out.

Note:

When baking and roasting with Circotherm® hot air, do not use shelf position 2. Air circulation is affected and the results of your baking and roasting are impaired.

Accessories

Your appliance is equipped with the following accessories:

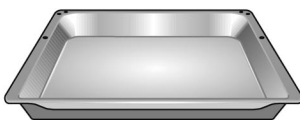

Enamelled universal pan

for baking, roasting, grilling and collecting dripping liquids

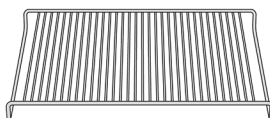

Grill

for roasting and grilling, can be inserted in the universal pan

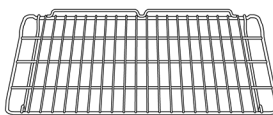

2 x wire racks, flat with tilt protection

for baking

Slide the flat wire racks in so that the rear upstand, is at the rear and facing upwards (see illustration below). Tilt protection only operates in this position.

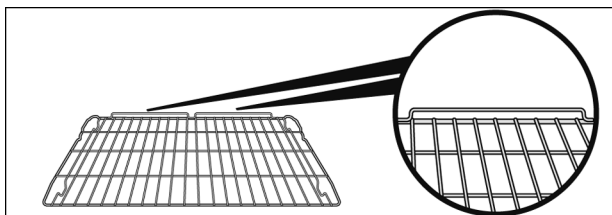

You can obtain further accessories from specialist retailers:

Accessories	Order no.
System steamer	N8642X0EU
Glass pan	Z1262X0
Enamelled roasting pan	Z1272X0
Baking and roasting shelf, close meshed	Z1452X0
VarioCLOU telescopic railings retrofit kit	Z1784X0

Accessories	Order no.
Bread-baking stone	Z1912X0
Enamelled universal roasting dish	Z9930X0

Note:

The baking tray and universal pan may become distorted during use. This is caused by the considerable temperature differences on the accessories. This may happen when only a part of the accessory is covered with food or when frozen items such as pizza have been placed on the accessory.

Before using the appliance for the first time

This section contains information on

- how to set the time on your appliance after the power is connected
- how to clean your appliance before using it for the first time

Setting the time

0:00 flashes in the clock display.



1. Press the clock function button.
The ◀▶ and ⌚ symbols are lit.
The clock display shows *12:00*.
2. Set the current time using the rotary selector.
Your setting is automatically adopted after 3 seconds.

Changing the time

To subsequently change the time, press the clock function button repeatedly until the ◀▶ and ⌚ symbols are lit. Change the current time using the rotary selector.

Cleaning the appliance

Clean your appliance before using it for the first time.

1. Remove the accessories from the cooking compartment.
2. Completely remove any residual packaging (e.g. chips of polystyrene) from the cooking compartment.
3. Clean the accessories and cooking compartment with hot soapy water (see section: Cleaning and care).
4. Heat with top/bottom heating  at 240 °C for 30 minutes.
5. Afterwards, wipe the cooled cooking compartment with hot, soapy water.
6. Clean the outside of the appliance with a soft, damp cloth and soapy water.

Using the appliance

This section contains information on



- how to switch your appliance on and off
- how to select an operating mode and temperature
- how you can change the basic settings
- when your appliance switches off automatically





Switching on the appliance











1. Turn the operating mode selector until the desired operating mode is selected.
In the temperature display, a default temperature is shown.
2. Turn the temperature selector to change the default temperature.

Notes:

- The operating modes  EasyClean® and  Low-temperature cooking can only be started if neither *H* nor *h* are shown in the display.
- If no default temperature is displayed, the temperature of your selected operating mode is a fixed setting. You cannot change this temperature.

Operating mode	Default temperature in °C	Temperature range in °C
 Circotherm® hot air	160	40 - 200
 Top/bottom heating	170	50 - 275
 Circotherm intensive	220	50 - 275
 Circo-roasting	170	50 - 250
 Large grill	220	50 - 275

* Turn the temperature selector beyond 275 °C.
int appears in the temperature display.

Operating mode	Default temperature in °C	Temperature range in °C
 Large grill (intensive)*	Fixed setting	
 Small grill	180	50 - 275
 Small grill (intensive)*	Fixed setting	
 Bottom heating	200	50 - 225
 Low-temperature cooking	Fixed setting	
 Defrost setting	Fixed setting	
 Easy Clean®	Fixed setting	
 Cooking compartment lighting	Fixed setting	

* Turn the temperature selector beyond 275 °C. *int* appears in the temperature display.

Current temperature

With operating modes that have a default temperature, you can display the current temperature during the heating up phase.

Press the info button. The current temperature appears for 3 seconds.

Heating control

The heating control displays the rising temperature in the cooking compartment.



- Temperature reached (figure A)
- Appliance reheating to temperature (figure B)

Switching off the appliance

Turn the operating mode selector to the **o** position.
The appliance is switched off.

The appliance has a cooling fan. After the appliance is switched off, the cooling fan may continue to run.

Residual heat indicator

You can see in the temperature display whether there is a high or low residual heat in the cooking compartment.

Temperature display	Meaning
<i>H</i>	Residual heat high (above 120 °C)
<i>h</i>	Residual heat low (between 60 °C and 120 °C)

Changing the basic settings

Your appliance has various basic settings that have been pre-set by the manufacturer. However, you can change these basic settings as required.

The appliance must be switched off and controls not locked.

1. Press and hold the info button for 3 seconds to reach the basic settings menu.
c  appears in the temperature display.
2. Press the info button briefly and repeatedly until the setting symbol for the current basic setting of a submenu is displayed in the temperature display (e.g. *c 32*).
3. Using the temperature selector, set the required basic setting within a submenu (e.g. *c 33*).
4. Press and hold the info button for 3 seconds.
Your basic setting is saved.

You can change the following basic settings:

Basic settings menu		
Submenu	Basic setting	Setting symbol (temperature display)
Childproof lock	Lock is not activated	<i>c 10</i>
	Lock is activated	<i>c 11</i>
	Permanent lock is activated	<i>c 21</i>

Submenu	Basic setting	Setting symbol (temperature display)
Audible signal on/off	Audible signal off	<i>c 30</i>
	Audible signal duration 30 seconds	<i>c 3 1</i>
	Audible signal duration 2 minutes	<i>c 3 2</i>
	Audible signal duration 10 minutes	<i>c 3 3</i>

Automatic safety switch off

The automatic safety switch off is activated if your appliance is switched on and you have not made any settings for a long time.

You can adjust the period of time after which your appliance shuts off.

000 flashes in the temperature display. Appliance operation is interrupted.

Deactivating

Turn the operating mode selector back to the *o* position.

Electronic clock

This section contains information on

- how to set the minute minder
- how to switch your appliance off automatically (operating time and end of operation)
- how to switch your appliance on and off automatically (preselection operation)
- how to set the time
- how to activate rapid heating

Clock display

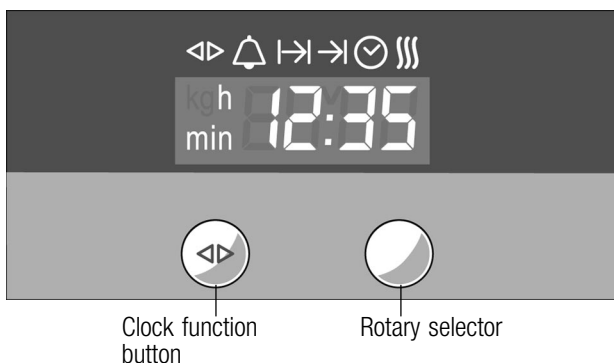

Clock function	Use
Timer	You can use the timer as an egg timer or a kitchen timer. The appliance does not switch on or off automatically.
Cooking time	The appliances switches off automatically after a cooking time setting has elapsed (e.g. <i>1:30</i>).
End of operation	The appliance switches off automatically at a set time (e.g. <i>12:30</i>).
Preselection mode	The appliance switches on and off automatically. Cooking time and end of operation are combined.
Clock	Sets the clock
Rapid heating	Shortens the preheat time

Notes:

- Between *22:00* and *5:59*, the clock display is darkened if you do not alter any settings during this time or if no clock function is activated.
- For the timer, cooking time, end of operation and preselection mode clock functions, a signal sounds when the duration has elapsed and the or symbol flashes. To cancel the audible signal before it ends, press the clock function button.

Switching the clock display on and off

1. Press and hold the clock function button for 6 seconds.
The clock display switches off. If a clock function is active, the associated symbol remains lit.
2. Press the clock function button briefly.
The clock display switches on.

Timer



1. Press the clock function button repeatedly until the $\leftarrow \rightarrow$ and \triangle symbols light up.
2. Use the rotary selector to set the cooking time (e.g. **5:00** minutes).
The setting is accepted automatically. Then the clock is displayed again and the timer starts counting down.

Cooking time

Automatic switch-off after a cooking time setting has elapsed.



1. Set the operating mode and temperature.
The appliance heats up.
2. Press the clock function button repeatedly until the ◀▶ and I→ symbols light up.
3. Use the rotary selector to set the cooking time (e.g. 1:30 hours).
The setting is accepted automatically. Then the clock is displayed again and the cooking time setting starts counting down.

Once the cooking time has expired, the appliance switches off automatically.

4. Reset the operating mode selector to the 0 position.
5. Press the clock function button to quit the clock function.

End of operation

Automatic switch-off at a set time.



1. Set the operating mode and temperature.
The appliance heats up.
2. Press the clock function button repeatedly until the ◀▶ and →I symbols light up.
3. Use the rotary selector to set the end of operation (e.g. 12:30).
The setting is accepted automatically. The clock is then displayed again.

The appliance switches off automatically at the time set for the end of operation.

4. Reset the operating mode selector to the \circ position.
5. Press the clock function button to quit the clock function.

Preselection mode

The appliance switches on automatically, and switches off automatically at the end of the preselected time for the end of operation. To set this function, combine the clock functions cooking time and end of operation.

Bear in mind that food which spoils easily must not stay in the cooking compartment for too long.

1. Set the operating mode and temperature.
The appliance heats up.
2. Press the clock function button repeatedly until the \triangleleft and \rightarrow symbols light up.
3. Use the rotary selector to set the cooking time (e.g. **1:30** hours).
The setting is accepted automatically.
4. Press the clock function button repeatedly until the \triangleleft and \rightarrow symbols light up.
5. Use the rotary selector to set the time for the end of operation (e.g. **12:30**).
The appliance switches off and waits until the correct time to switch on (in the example, **11:00**).



The appliance switches off automatically at the time set for the end of operation (**12:30**). A signal sounds and the \rightarrow symbol flashes.

6. Reset the operating mode selector to the \circ position.
7. Press the clock function button to quit preselection mode.

Setting the time

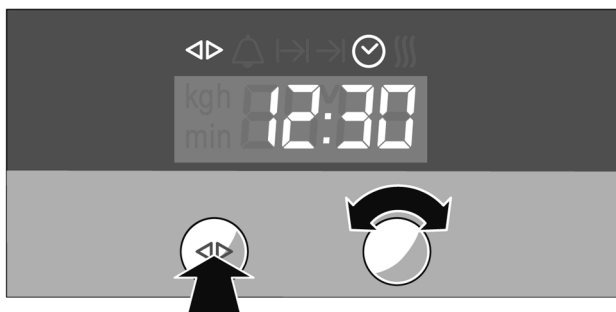
You can only change the clock, when no other clock functions are active.









1. Press the clock function button repeatedly until the  and  symbols light up.
2. Set the time using the rotary selector.
The setting is accepted automatically.

Rapid heating

With  CircoTherm®, you can shorten the preheat time if your selected temperature setting is higher than 100 °C.

Note:

During rapid heating, do not place any food in the cooking compartment for as long as the  symbol is lit.

1. Set the operating mode and temperature.
The appliance heats up.
2. Press the clock function button repeatedly until the  and  symbols are lit and  appears on the clock display.
3. Turn the rotary selector to the right.
 is displayed on the clock display and the  symbol lights up. Rapid heating is activated.



After reaching the set temperature, rapid heating switches off. The ||| symbol goes out.

Checking, correcting or deleting settings

1. To check your settings, press the clock function button repeatedly until the corresponding symbol lights up.
2. If necessary, you can correct your settings using the rotary selector.
3. If you want to delete your settings, turn the rotary selector to the left, back to the original value.

Childproof lock

In this section you can learn

- how to lock your appliance
- how to lock your appliance permanently

Locking

The locked appliance cannot be switched on accidentally or by unauthorised users (e.g. playing children).

To switch the appliance on again, you must unlock it. After appliance operation, the appliance is not automatically locked. Lock it again if necessary or activate the permanent lock.

Lock the appliance

1. Switch off the appliance.
2. Press and hold the info button until **⌂** **!** appears in the temperature display.
3. Turn the temperature selector until **⌂** **!!** appears in the temperature display.
4. Press and hold the info button until the **↔** symbol appears in the temperature display.

Note:

If you try to switch the locked appliance on, **-5-** appears in the temperature display.

Unlock the appliance

1. Press and hold the info button until **⌂** **!!** appears in the temperature display.
2. Turn the temperature selector until **⌂** **!** appears in the temperature display.
3. Press and hold the info button until the **↔** symbol goes out.

Permanent lock

The permanently locked appliance cannot be switched on accidentally or by unauthorised users (e.g. playing children).

To switch the appliance on, you must interrupt the permanent lock briefly. After you have switched your appliance off, it locks again automatically.

Lock appliance permanently

1. Switch off the appliance.
2. Press and hold the info button until **⌂** **!** appears in the temperature display.
3. Turn the temperature selector until **⌂** **?!** appears in the temperature display.
4. Press the info button for 3 seconds.
Your appliance will be locked after 30 seconds. The **↔** symbol appears in the temperature display.

Note:

If you try to switch the locked appliance on, **-SP-** appears in the temperature display.

Interrupt permanent lock

1. Press and hold the info button until **c 2 !** appears in the temperature display.
2. Turn the temperature selector until **c 20** appears in the temperature display.
3. Press and hold the info button until the **↔** symbol goes out.
The permanent lock is interrupted.
4. Switch the appliance on within 30 seconds.

After switching off, the permanent lock is activated again after 30 seconds.

Unlock the appliance permanently

1. Press and hold the info button until **c 2 !** appears in the temperature display.
2. Turn the temperature selector until **c 20** appears in the temperature display.
3. Press and hold the info button until the **↔** symbol goes out.
4. Within 30 seconds, press and hold the info button again for 3 seconds.
5. Turn the temperature selector until **c !0** appears in the temperature display.
6. Press the info button for 3 seconds.
The appliance is permanently unlocked.

Baking

In this section, you will find information on

- Baking on one level
- Baking on two or more levels
- The baking table
- The baking table for pre-prepared products
- Tips and tricks for baking

Note:

When baking with  CircoTherm®, do not use shelf height 2. The air circulation would be impaired and this will have a negative effect on your baking.

We recommend that you use dark baking tins made from metal.

Tinplate and glass dishes increase the baking time required and the cake will not brown evenly.

If you wish to bake using tinplate dishes and  Top/bottom heat, you should use shelf height 1.

Always slide the universal pan in carefully as far as it will go and make sure that the sloping edge is facing the appliance door.

Slide a wire rack in so that the rear upstand to prevent items sliding off the back of the shelf is at the rear. This prevents baking tins slipping off the back.

Baking on one level

If you are baking on one level with  CircoTherm®, always place a round baking tin in the centre (Figure A) and a loaf tin diagonally (Figure B) on the flat wire rack.

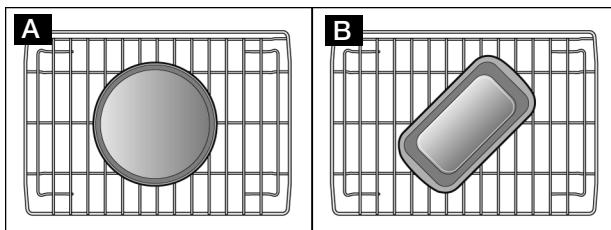

If you are baking on one level with  CircoTherm®, always place two round baking tins diagonally from each other on the flat wire rack (Figure C).

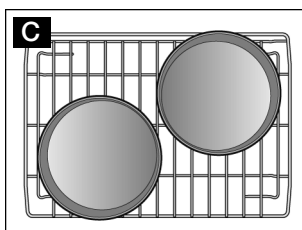

Baking on two or more levels

Two baking tins on two levels

If you are baking on more than one level, only use the  CircoTherm® operating mode.

Bear in mind that your items may brown at different rates on each level. The items on the top level will brown most quickly and can be taken out earlier.

If you are baking with two round baking tins or two baking trays, insert the flat wire racks at shelf heights 1 and 3.

Place the lower baking tin to the left (Figure A) and the upper baking tin to the right (Figure B) on their respective wire racks.

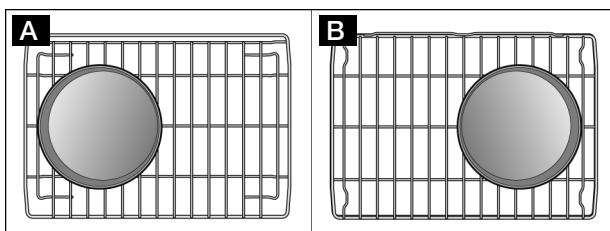

Four baking tins on two levels

If you are baking with four round baking tins, insert the flat wire racks at shelf heights 1 and 3.

Place the lower baking tins diagonally from each other as shown in Figure C and the upper baking tins diagonally from each other as shown in Figure D on their respective wire racks.

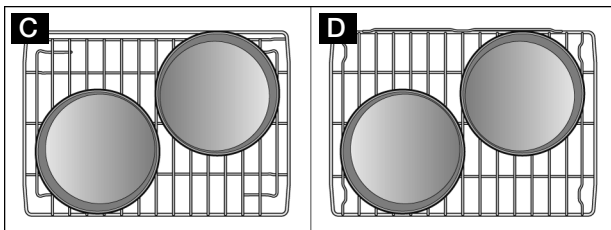

Baking table

































The values in the table are average values and apply to dark baking tins. The values may vary depending on the type and amount of dough/mixture and on the baking tin.

We recommend that you set the lower of the specified temperatures the first time. This will generally allow more even browning.

If you are baking with your own recipe, use similar recipes in the table as a guide.









Observe the notes in the table about preheating.

Meal	Setting	Level	Temperature in °C	Time in minutes
Victoria sponge cake				
■ 1 level		1	160 - 170*	25 - 30
■ 1 level		2	160 - 170*	20 - 30
■ 2 levels		1 + 3	150 - 160*	25 - 35
Scones				
■ 1 level		1	180 - 200*	10 - 15
■ 1 level		3	210 - 220*	8 - 10
■ 2 levels		1 + 3	180 - 200*	10 - 15
* Preheat oven				
** Preheat the oven to 130 °C				

Meal	Setting	Level	Temperature in °C	Time in minutes
Small cakes				
■ 1 level		1	160 - 170*	20 - 30
■ 1 level		3	150 - 160*	25 - 35
■ 2 levels		1 + 3	150 - 160*	25 - 35
Light fruit cake				
		1	140 - 150*	80 - 100
Rich fruit cake				
		1	140 - 150*	210 - 240
Jamtartes				
■ 1 level		1	190 - 200*	15 - 20
■ 1 level		3	200 - 210*	15 - 20
■ 2 levels		1 + 3	190 - 200*	20 - 25
Swiss roll				
		1	180 - 190*	10 - 15
		2	190 - 200*	10 - 15
Tart				
■ 1 level		1	160 - 170*	50 - 60
■ 1 level		1	180 - 190*	45 - 55
■ 2 levels		1 + 3	160 - 170*	50 - 60
Pies				
■ 1 level		1	170 - 180*	65 - 75
■ 1 level		1	170 - 180*	65 - 75
■ 2 levels		1 + 3	170 - 180*	65 - 75
Biscuits				
■ 1 level		1	160 - 170*	15 - 20
■ 1 level		2	170 - 180*	15 - 20
■ 2 levels		1 + 3	160 - 170*	20 - 25
■ 3 levels		1 + 3 + 4	160 - 170*	20 - 25
Baiser				
		1	80*	100 - 130
		3	80*	100 - 130
Pavlova				
		1	90 - 100**	90 - 120
		3	80 - 90**	90 - 120
Fruit crumble				
		1	170 - 180*	45 - 55
		2	190 - 200*	45 - 55
Yorkshire pudding				
■ 1 level		2	220 - 230*	15 - 20
■ 1 level		1	210 - 220*	10 - 15
■ 2 levels		1 + 3	200*	15 - 20
Vol au vents				
		1	190 - 200*	20 - 30
		1	180 - 190*	20 - 25
Quiche				
		1	180 - 200*	45 - 55
		1	180 - 190*	30 - 40

* Preheat oven

** Preheat the oven to 130 °C

Meal	Setting	Level	Temperature in °C	Time in minutes
(White) bread				
■ 1 level		1	220 - 230*	20 - 25
■ 1 level		1	200 - 220	20 - 25
Homemade pizza				
■ 1 level		1	190 - 200*	20 - 30
■ 1 level		1	180 - 190*	15 - 20
■ 2 levels		1 + 3	180 - 190*	35 - 45
Jacket potatoes				
■ 1 level		1	160 - 170	60 - 70
■ 1 level		1	160 - 170	50 - 55
■ 2 levels		1 + 3	160 - 170	65 - 75
* Preheat oven				
** Preheat the oven to 130 °C				

Baking table for pre-prepared products

Please note the following points for pre-prepared products:

























- Use the universal pan
- Only use greaseproof paper that is suitable for the selected temperature
- Spread chips out in a single layer
- Turn frozen potato products half way through the baking time
- Only season frozen potato products after they have finished baking
- Leave a little space between bread rolls when crisping them up. Do not place too many in the universal pan
- Cover lasagne with plenty of cheese, so that the top browns evenly
- Do not use frozen products with freezer burn
- Do not use frozen products that are heavily frosted
- Follow the manufacturer's instructions

The values in the table are average values and apply to the universal pan.

We recommend that you set the lower of the specified temperatures the first time. This will generally allow more even browning.

When baking on several levels, only use the  CircoTherm® operating mode.

Observe the notes in the table about preheating.

Meal	Setting	Level	Temperature in °C	Time in minutes
Frozen pizza				
■ 1 level		1	180 - 200*	15 - 25
■ 1 level		1	180 - 200*	10 - 20
■ 2 levels		1 + 3	170 - 190*	20 - 30
Chilled pizza				
■ 1 level		2	190 - 210*	10 - 15
■ 1 level		1	190 - 200*	10 - 15
Part-baked white bread				
■ 1 level		1	180 - 190*	10 - 20
■ 1 level		1	180 - 190*	5 - 15
■ 2 levels		1 + 3	170 - 180*	15 - 20
French fries		1	180 - 200*	25 - 30
French fries		1	180 - 190*	20 - 25
Potato wedges		1	180 - 190*	20 - 25
Potato wedges		1	180 - 190*	15 - 20
Croquettes		1	180 - 190*	25 - 30
Croquettes		1	180 - 190*	20 - 25
Fish fingers		1	180 - 200*	15 - 20
Fish fingers		1	180 - 200*	10 - 15
Lasagne, frozen (400 g)		1	180 - 190*	40 - 45
Lasagne, frozen (400 g)		1	180 - 190*	35 - 40
Lasagne, frozen (1200 g)		1	180 - 190*	45 - 50
Lasagne, frozen (1200 g)		1	180 - 190*	40 - 45
Lasagne, chilled (400 g)		1	170 - 180*	35 - 40
Lasagne, chilled (400 g)		2	190 - 200*	35 - 40
Lasagne, chilled (1200 g)		1	170 - 180*	40 - 45
Lasagne, chilled (1200 g)		2	190 - 200*	40 - 45

* Preheat oven

Tips and tricks

The cake is too light in colour	<p>Check the shelf height.</p> <p>Check whether you have used the bakeware that we have recommended.</p> <p>Place your tin on the wire rack and not on the baking tray.</p> <p>If the shelf height and the bakeware are correct, then you should either extend the baking time or increase the temperature.</p>
The cake is too dark	<p>Check the shelf height.</p> <p>If the shelf height is correct, you should either shorten the baking time or reduce the temperature.</p>
The cake is unevenly browned in the baking tin	<p>Check the shelf height.</p> <p>Check the temperature.</p> <p>Make sure that your baking tin is not placed directly in front of the air outlets in the rear wall of the cooking compartment.</p> <p>Check that the baking tin is correctly positioned on the wire rack.</p>
The cake is too dry	<p>Set a slightly higher temperature and a slightly shorter baking time.</p>
The cake is too moist in the centre	<p>Set a slightly lower temperature.</p> <p>Note: you cannot decrease the baking time by setting a higher temperature (the outside will be cooked, but the inside will remain uncooked).</p> <p>Select a longer baking time and allow the cake mixture to prove for longer.</p> <p>Add less liquid to the mixture.</p>
The cake collapses when you take it out of the oven	<p>Use less liquid for the mixture.</p> <p>Set a longer baking time or a slightly lower temperature.</p>
The specified baking time is not correct	<p>For small items, check the amount on the baking tray. The items must not be touching each other.</p>
Frozen products are not browned evenly after baking	<p>Check whether the frozen product is unevenly browned before baking. This uneven browning will remain after the baking time.</p>
Several cakes on one level are unevenly browned	<p>Check the position of the baking dishes on the wire rack.</p>

Frozen products are not browned, not crispy or the specified time is not correct

Remove ice from frozen products before baking. Do not use frozen products that are heavily frosted.

Saving energy

Only preheat the appliance when it is specified in the baking table that you should do so.

Use dark baking tins as these absorb the heat better.

Make use of the residual heat with longer baking times and switch the oven off 5 - 10 minutes before the end of the baking time.

Roasting and braising

In this section, you will find information on

- Roasting
- Braising
- Tables for roasting and braising
- Tips and tricks



There is a risk of injury if you use roasting dishes that are not heat-resistant. Only use roasting dishes that are marked as being suitable for use in the oven.

Note:

When roasting with  CircoTherm®, do not use shelf height 2. The air circulation would be impaired and this will have a negative effect on your roast.

Roasting

Cookware without a lid is used for roasting.

When you are roasting with  Top/bottom heat, you should turn the roast approximately half to two thirds of the way through the roasting time.

Roasting in the universal pan

Juices escape from the roasting meat and are collected in the universal pan. You can use these juices as the basis for a tasty gravy.

Deglaze the pan of the juices with hot water, stock, wine or similar, bring it to the boil, thicken with cornflour, season and pass through a sieve if necessary.

You can also cook side dishes (e.g. vegetables) at the same time as roasting meat in the universal pan.

Note:

For smaller joints, you can use a smaller roasting dish instead of the universal pan. Place this directly on the wire rack.

Place the insert grid in the universal pan and slide them in together at the same shelf height.

For fatty meat and poultry, add $\frac{1}{8}$ to $\frac{1}{4}$ litre of water to the universal pan, depending on the size and type of the joint.

While the meat is roasting, the liquid in the roasting dish will evaporate. Pour in more hot water if required.

Roasting in the universal pan with insert grid

Braising

For braising, a roasting dish with a lid is used. Ensure that the roasting dish and lid are designed for one another and fit closely.

First, sear the meat if required.

Add the meat, vegetables and liquid to the roasting dish in the proportion 1:1:1 and place it with the lid closed on the wire rack on shelf position 1.

While the meat is braising, the liquid in the roasting dish will evaporate. Pour in more liquid if required.

Tables for roasting and braising

Poultry

The values in the tables are only average values.

The information in the tables applies to unstuffed poultry. Turn the poultry after half of the cooking time.

Lean meat

Coat lean meat with fat or oil as required and cover it with strips of bacon.

Cooking time and temperature

The cooking time and temperature depend on the size, height, type and quality of the food and the roasting dish.

In general, the larger the joint, the lower the temperature and the longer the roasting time.





























You should set the lower of the specified temperatures the first time. This will generally allow more even browning.

The values for cooking time apply to 0.5 - 2 kg of food. For greater weights, reduce the temperature and increase the cooking time. For multiple pieces, apply the cooking time for the weight of the heaviest piece.

Standing time





At the end of the cooking time, switch the oven off and leave the roast to stand for approximately 10 minutes in the cooking compartment with the door closed. The recommended standing time is not included in the cooking times specified.







The information in the tables apply to food placed in a cold oven and for meat taken directly from the refrigerator.

Meal	Setting	Level	Temperature in °C	Time in minutes (per 500 g)
Beef				
Slow roast joint		1	140	40 + 40
Slow roast joint		2	150	40 + 40
Top side / top rump		1	160	30 + 25
Top side / top rump		2	190	30 + 25
Lamb				
Leg		1	170	30 + 25
Leg		2	200	30 + 25
Shoulder (bone-in)		1	170	25 + 20
Shoulder (bone-in)		2	200	25 + 20
Shoulder (boned and rolled)		1	170	30 + 25
Shoulder (boned and rolled)		2	200	30 + 25
Rack of lamb		1	180	25 + 25
Rack of lamb		2	200	25 + 25
Pork				
Roast joint		1	180	35 + 35
Roast joint		2	180	35 + 35
Loin joint		1	180	30 + 30
Loin joint		2	180	30 + 30
Belly		1	160	30 + 25
Belly		2	190	30 + 25
Gammon				
Joint		1	160	30 + 30
Joint		2	190	30 + 30
Chicken				
Whole chicken		1	170 - 180	20 + 25
Whole chicken		2	190 - 200	20 + 25
Portion (boned)		1	190	20 + 25
Portion (boned)		2	200 - 210	20 + 25
Quarter		1	190	20 + 25
Quarter		2	200 - 210	20 + 25
Duck		1	180	20 + 20
Duck		2	190 - 200	20 + 20

* Preheat oven

** + time for yorkshire pudding

Meal	Setting	Level	Temperature in °C	Time in minutes (per 500 g)
Turkey				
Drumstick		1	180	20 + 20
Crown		1	160	25 + 20
Whole		1	150 - 160	25 + 25
Complete Meal				
with beef		1 + 3	160	30 + 25**
* Preheat oven				
** + time for yorkshire pudding				

Casseroles	Setting	Level	Temperature in °C	Time in minutes (per 500 g)
Diced meat (beef, pork, lamb, chicken)		1	140	40 + 80
Diced meat (beef, pork, lamb, chicken)		1	140*	40 + 80
Braising steak		1	140	45 + 80
Braising steak		1	140*	45 + 80
Chicken pieces (boned)		1	140	50 + 70
Chicken pieces (boned)		2	140	50 + 70
* Preheat oven				



Tips and tricks

Crust too thick and/or roast too dry	Reduce the temperature or shorten the roasting time. Check the shelf height.
Crust too thin	Increase the temperature or switch on the grill briefly at the end of the roasting time.
The meat is not cooked right through	Remove any accessories that are not required from the cooking compartment. Increase the roasting time. Check the core temperature of the joint using a meat thermometer.

Steam in the cooking compartment is condensing on the appliance door	The steam dries during the course of the cooking. If there is an excessive volume of steam, you can carefully open the door briefly to dissipate the steam more quickly.
The meat is burned slightly during braising	Add the meat, vegetables and liquid to the roasting dish in the proportion 1:1:1. The roasting dish and lid must be designed for one another and fit closely. Reduce the temperature.

Grilling

In this section, you will find information on

- grilling in general
-  circo-roasting
- radiant grilling ( large grill and  small grill)
- the grilling table

Caution

There is a risk of damage to kitchen units if you grill with the appliance door open. The adjacent units may be damaged by the extreme heat. Keep the appliance door closed when using the grill.

Notes:

- Always use the insert grid and universal pan for grilling.
- Place the insert grid into the universal pan and slide the two in together at the height specified in the grilling table.
- Always place the food to be grilled in the centre of the insert grid.
- If you are grilling more than one piece of meat, make sure that they are the same sort of meat and that they are of similar thickness and weight.

Circo-roasting

The  Circo-roasting operating mode is particularly suitable for grilling poultry and meat so that it is crispy (e.g. roast pork with crackling).

Turn large items of food after approximately half to two-thirds of the grilling time. Place food with a crust on the wire rack with the crust side down for the first half of the grilling time.

Pierce duck and goose skin under the wings and legs to allow the fat to escape.

Depending on the food you are cooking, the cooking compartment may become very dirty when you cook food on the wire rack using Circo-roasting. You should therefore clean the cooking compartment after every use so that the dirt does not burn on.

At the end of the cooking time, switch the oven off and leave the food to rest for approximately 10 minutes in the cooking compartment with the door closed. The recommended rest time is not included in the grilling times specified.

Radiant grilling

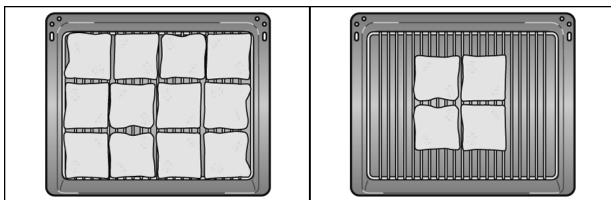

For large amounts of flat grill items, use the  large grill (Figure A).

For small amounts of flat grill items, use the  small grill. Place the food to be grilled in the centre of the insert grid (Figure B). Using the small grill operating mode will save energy.

Brush the items to be grilled with a little oil to taste.













Turn the items after half to two-thirds of the grilling time.

Grilling table

The information in the table are guidelines and apply to the enamelled universal pan with stepped wire rack. The values may vary depending on the type and amount of food to be grilled.

You should set the lower of the specified temperatures the first time. This will generally allow more even browning.







The values are for food placed in a cold oven and for meat taken directly from the refrigerator.

Meal	Setting	Level	Temperature in °C	Time in minutes
Beef				
Steaks, high 2- 3 cm		4	<i>int</i> *	1st side: 9 - 12 2nd side: 5 - 7
Burgers, high 1 - 2 cm		4	<i>int</i>	1st side: 8 - 10 2nd side: 6 - 8
Lamb				
Leg		2	170 - 190	120 - 150***
Shoulder (bone-in)		2	170 - 190	100 - 130***
Shoulder (boned and rolled)		2	170 - 190	120 - 150***
Steaks, high 2 - 3 cm		4	<i>int</i>	1st side: 5 - 7 2nd side: 3 - 5
Chops, high 2 - 3 cm		4	<i>int</i>	1st side: 6 - 8 2nd side: 4 - 7
Pork				
Roast joint		2	180 - 200	120 - 150***
Steaks, high 1 - 2 cm		4	<i>int</i> *	1st side: 8 - 10 2nd side: 5 - 8
Chops, high 2 - 3 cm		4	<i>int</i>	1st side: 10 - 12 2nd side: 8 - 10
Burgers, high 1 - 2 cm		4	<i>int</i>	1st side: 8 - 10 2nd side: 6 - 8
Sausages, ø 2 - 4 cm		4	<i>int</i>	12 - 16**
Gammon				
Steaks, high 1 - 2 cm		4	<i>int</i>	1st side: 9 - 12 2nd side: 5 - 7

* Preheat for 3 minutes

** Turn frequently

*** Turn after half of the time

Meal	Setting	Level	Temperature in °C	Time in minutes
Chicken				
Drumsticks		3	250	1st side: 15 - 17 2nd side: 10 - 13
Breast (boneless)		4	250	1st side: 12 - 15 2nd side: 7 - 10
Whole chicken		2	200 - 220	70 - 90***
Quarter		2	210 - 230	40 - 50***
Fish				
Whole fish, e.g. trout		3	220	1st side: 10 - 15 2nd side: 10 - 15
Whole fish, e.g. trout		2	220	15 - 25
Filets		4	220	1st side: 8 - 12 2nd side: 7 - 10
* Preheat for 3 minutes				
** Turn frequently				
*** Turn after half of the time				

Low-temperature cooking

In this section, you will find information on

-  Low-temperature cooking
- tips and tricks

Low-temperature cooking is a method of cooking slowly at low temperatures, and is also known as slow cooking.

Low-temperature cooking is ideal for all prime cuts of meat (e.g. tender portions of beef, veal, pork, lamb and poultry) that are to be cooked medium or medium rare. The meat will remain succulent and tender.

Using Low-temperature cooking



Please observe the following points:

- Only use fresh, cleaned meat
- The meat will always look pink on the inside after low-temperature cooking. This does not mean that the cooking time was too short
- Only use boned meat
- Do not use defrosted meat
- You can also use seasoned or marinated meat
- Always use shelf height 1 for low-temperature cooking
- Do not cover the meat while it is cooking in the cooking compartment
- Do not turn pieces of meat during the low-temperature cooking process
- The size, thickness and type of meat will have a significant influence on the searing and low-temperature cooking times
- The properties of the pan and the heat output of the hotplate can influence the searing time
- Do not use the low-temperature cooking setting together with the preselection mode clock function

Only switch the low-temperature cooking setting on when the cooking compartment has completely cooled down (room temperature).

If **H** or **h** and **|||** appear alternately in the temperature display after switching on the slow cooking operating mode, the cooking compartment has not cooled down completely.

Wait until the cooking compartment has cooled down and switch Low-temperature cooking on again.

1. Insert a glass or ceramic plate on a wire rack into the cooking compartment at shelf position 1 to preheat the plate.
2. Switch on the  Slow cooking operating mode. **III** appears in the temperature display during the heating up phase (15 to 20 minutes).
3. Remove the fat and sinews from the meat.
4. Sear the meat on all sides over a high heat to seal the meat and create a roasted flavour.
5. When a signal sounds and  appears in the temperature display, place the meat on the glass or porcelain plate in the cooking compartment.
6. Remove the food once the cooking time has elapsed and switch off the appliance.

Note:

Slow-cooked meat does not need to be rested and can be kept warm at a low temperature without any problems.

Table for Low-temperature cooking

The information in the table is only a guideline. The searing time is for searing in a hot pan with fat.

You can find information on how to proceed, further instructions and recipes in the accompanying cookbook.

	Searing in minutes	Low-temperature cooking in minutes
Pork		
Fillet, whole (approx. 500 g)	5 - 6	100 - 120
Loin (approx. 1 kg, 4 - 5 cm thick)	5 - 6	120 - 150
Medallions (5 cm thick)	3 - 4	45 - 60
Loin steaks (2 - 3 cm thick)	2 - 3	30 - 45
Beef		
Fillet, whole (1.5 kg)	6 - 7	160 - 200
Sirloin (approx. 1.5 kg, 5 - 6 cm thick)	6 - 7	180 - 210
Centre-cut rump (6 - 7 cm thick)	6 - 7	240 - 300

* well-done

** see the note below

	Searing in minutes	Low-temperature cooking in minutes
Medallions (5 cm thick)	3 - 4	60 - 80
Rump steak (3 cm thick)	3 - 4	50 - 70
Steak-cut rump (3 cm thick)	3 - 4	50 - 70
Veal		
Fillet, whole (approx. 800 g)	4 - 5	150 - 180
Flank (approx. 2 kg, 8 - 9 cm thick)	6 - 7	360 - 420
Centre-cut rump (approx. 1.5 kg, 4 - 5 cm thick)	6 - 7	240 - 300
Medallions (4 cm thick)	3 - 4	70 - 90
Lamb		
Loin, boned (approx. 200 g)	2 - 3	30 - 40
Leg, boned (approx. 1 kg)	6 - 7	240 - 300
Poultry		
Chicken breast (150 - 200 g)*	4 - 5	90 - 120
Duck breast (300 - 400 g)**	10 - 12	70 - 90
Turkey breast (1 kg)*	4 - 5	150 - 180
Turkey steaks (2 - 3 cm)*	3 - 4	40 - 60
* well-done		
** see the note below		

Note:

Place the duck breast in a cold pan and fry the skin side first. Following low-temperature cooking, insert at shelf height 3 and grill at 250 °C for 3 - 5 minutes until crispy.

Tips and tricks

Slow-cooked meat cools down too quickly



Serve on preheated plates with a piping hot sauce.

Keeping slow-cooked meat warm

Switch on Top/bottom heat and set the temperature at 60 °C. Small pieces of meat can be kept warm for up to 45 minutes and large pieces for up to 2 hours.

Defrosting

In this section, you can read about

- how to defrost with Circotherm® hot air 
- how to use the defrost setting 

Defrosting with Circotherm® hot air

Use Circotherm® hot air  to defrost and cook frozen products. Please note the following points here:

- Frozen products that have been defrosted (meat in particular) require shorter cooking times than fresh products
- The cooking time for frozen meat increases by the defrosting time
- Always defrost frozen poultry before cooking, so that the giblets can be removed
- Cook frozen fish at the same temperatures as fresh fish
- You can place large quantities of ready made frozen vegetables in aluminium dishes in the cooking compartment at the same time
- Use shelf position 1 when defrosting on one level, and shelf positions 1 + 3 when using two levels
- Observe the manufacturer's instructions when using frozen foods

Defrost table

Frozen meals	Temperature in °C	Defrosting time in minutes
Raw frozen products/ foods	50	30 -90
Bread/bread rolls (750 - 1500 g)	50	30 - 60
Dry, frozen tray bakes	60	45 - 60
Moist, frozen tray bakes	50	50 - 70

Defrost setting

With this operating mode you can defrost delicate baked goods (e.g. cream cakes) particularly well.

1. Switch on the defrost setting .
2. Defrost frozen products for 25 - 45 minutes, depending on the type and size.
3. Remove the frozen product from the cooking compartment and allow it to defrost for a further 30 - 45 minutes.



Note:

With small quantities (pieces) the defrosting time is shortened to 15 - 20 minutes and the extended defrosting time is shortened to 10 - 15 minutes.

Yoghurt

You can also make yoghurt by yourself with your appliance: The heat from the interior lighting  is used for this.

1. Remove accessories and hook-in racks, telescopic shelves or separate fitting systems.
2. Heat 1 litre UHT milk (3.5 % fat) or pasteurised fresh milk to 40 °C
or
Bring 1 litre fresh milk to the boil once and allow to cool down to 40 °C.
3. Add 300 g firm yoghurt to the warm milk, stir in and fill the jars or bowls evenly. Do not fill more than 200 ml in a container.
4. Cover the filled containers with a suitable lid or cling film.
5. Distribute the containers on the entire cooking compartment floor, evenly spaced out.

6. Close the appliance door and switch on the interior lighting .
7. Switch off the interior lighting  after 7 hours and place the containers in the refrigerator for at least 18 hours.

Cleaning and care

In this section, you will find information on

- cleaning and care of your appliance
- cleaning agents and aids
- self-cleaning surfaces in the cooking compartment
- Easy Clean cleaning aid®



Risk of short-circuit. Do not use high-pressure cleaners or steam jet cleaners to clean your appliance.



Ensure that the appliance is switched off before replacing the lamp to avoid the possibility of electric shock.

Caution!

Damage to surfaces. Do not use sharp or abrasive cleaning agents. Do not use abrasive cleaning aids such as steel wool or scourers.

Note:

Highly recommended cleaning and care products can be purchased through our after-sales service. Observe the manufacturer's instructions.

Cleaning the appliance exterior

Steam cleaner is not to be used.

Appliance part/surface	Cleaning agent/aid
Stainless steel surfaces	Apply commercially available detergent with a soft, damp cloth or chamois leather; dry with a soft cloth. Use cleaners for matted stainless steel if very dirty.
Painted surfaces	Apply commercially available detergent with a soft, damp cloth or chamois leather; dry with a soft cloth.
Glass surfaces	Apply commercially available detergent with a soft, damp cloth or chamois leather; dry with a soft cloth. Do not use harsh abrasive cleaners or sharp metal scrapers to clean the oven door glass since they can scratch the surface, which may result in shattering of the glass.
Door panels	Use commercially available glass cleaner or apply commercially available detergent with a soft, damp cloth or chamois leather; dry with a soft cloth. The inner door panel on the appliance door has a coating which reduces the temperature and reflects the heat. The view through the appliance door is not impaired by this. When the appliance door is open this coating can have the effect of a light-coloured film. This is part of the design and is not due to any quality defect.

Cleaning the cooking compartment

Caution!

Damage to surfaces. Do not clean the appliance while still warm, even if using oven cleaners specially intended for this purpose.

Notes:

- Enamel is baked on at very high temperatures during manufacture. This can cause some slight colour variation. This is normal and does not affect proper functioning.
- The edges of thin trays cannot be completely enamelled. As a result, these edges can be rough. Anti-corrosion protection is still guaranteed, however.

Appliance part	Cleaning agent/aid
Enamel surfaces (smooth surfaces)	To facilitate cleaning you can switch on the interior lighting and detach the appliance door if necessary. Apply commercially available detergent or vinegar solution with a soft, damp cloth or chamois leather; dry with a soft cloth. Loosen baked on food residues with a damp cloth and detergent. We recommend using oven cleaning gel if the oven is very dirty. This can be applied neat to the stain. Leave the cooking compartment open to dry after cleaning.
Self-cleaning surfaces (rough surfaces)	Please observe the instructions in the section: Self-cleaning surfaces
Door seal	Hot soapy water
Hook-in rack/telescopic shelf	Hot soapy water
Accessories	Soak in hot soapy water, clean with a brush and sponge or wash in the dishwasher

Keeping the appliance clean

To avoid getting the cooking compartment dirty,

- clean the cooking compartment after each use, as dirt will bake on the next time it is heated up, and this can only be removed with difficulty
- always remove lime, grease, starch and egg-white stains immediately
- where possible use Circotherm® hot air . This operating mode creates less dirt
- use the universal pan to bake very moist cakes
- use suitable ovenware when roasting (e.g. roasting dish) or a roasting sheet (see the section: Accessories)

Self-cleaning surface

The rear wall of the cooking compartment is coated with self-cleaning enamel. This coating absorbs and disintegrates splashes from baking and roasting while the oven is in operation.

Large splashes only disappear after the oven has been used several times.

Discolouration on the rear wall does not affect the self-cleaning function.

Caution

Damage to the self-cleaning surface due to the application of oven cleaner.

- Never clean the self-cleaning surface with oven cleaner.
- If oven cleaner is accidentally applied to the self-cleaning surface, remove it immediately with a sponge and plenty of water.

Caution

Damage to surfaces on self-cleaning areas due to the use of abrasive and acidic cleaning agents and aids.

- Do not use cleaning agents containing abrasive substances or acids.
- Do not use abrasive cleaning aids such as steel wool or scourers.

EasyClean®

Your appliance comes with an  EasyClean® function to make cleaning the cooking compartment easier. The automatically controlled vaporisation of soapy water loosens residues and makes it easier to remove them afterwards.

If very dirty, you can

- allow the soapy water to penetrate for a while before switching it on
- rub the dirty surfaces with detergent before switching on the cleaning aid
- repeat the EasyClean® function once the cooking compartment has cooled

Preparation and switching it on

EasyClean® only starts when the cooking compartment is cool.



Risk of burning and damage to surfaces.
Never pour water into the hot cooking compartment.
This creates water vapour, and the enamel may become damaged because of the change in temperature.

1. Remove the accessories from the cooking compartment.
2. Carefully pour 0.4 litres of water (not distilled water) with a little detergent into the base trough of the cooking compartment (Fig. A).
3. Close the appliance door.
4. Switch on  EasyClean®.

ECS appears in the temperature display.

If after switching on EasyClean® *H* or *h* and *ECS* appear alternately in the temperature display, the cooking compartment is not completely cooled.

Wait until the cooking compartment has cooled down and switch EasyClean® on again.

Once EasyClean® is complete the cooking compartment light switches on. A signal sounds.

5. Press the clock function button to end the clock function.

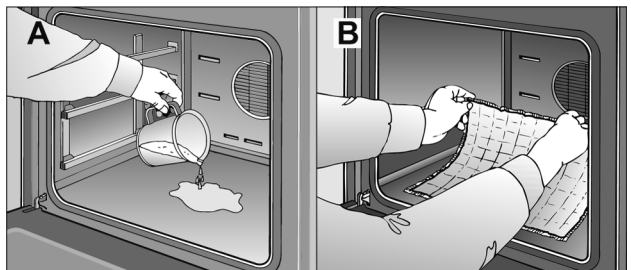

Cleaning and switching off

Do not leave the remaining water in the cooking compartment for a long time (e.g. overnight).

1. Open the appliance door and soak up the remaining water with an absorbent sponge cloth (Fig. B).
2. Clean the cooking compartment with a sponge cloth, a soft brush or a plastic pot scrubber.

Note:

Persistent and stubborn residues can be removed with a glass scraper for ceramic glass.

3. Remove limescale with a cloth soaked in vinegar, then wipe with clean water and rub dry with a soft cloth. Remember to dry under the door seal.
4. Move the operating mode selector back to the 0 position.
5. After cleaning, leave the appliance door in its slanted detent position (approx. 30°) for approx. 1 hour to allow the interior enamel surfaces to dry thoroughly.

Rapid drying

1. After cleaning, leave the appliance door in its slanted detent position (approx. 30°).
2. Set  CircoTherm® to 50 °C.
3. Switch off the appliance after 5 minutes and close the appliance door.

Removing and fitting the appliance door



Risk of injury!

The hinges on the appliance door can snap back with great force. Always open the locking lever on the hinge fully when removing the appliance door and close it again fully after fitting it. Do not reach into the hinge.



Risk of injury!

If the appliance door is detached on one side, do not reach into the hinge. The hinge can snap back with great force. Call the after-sales service.

Removing the appliance door

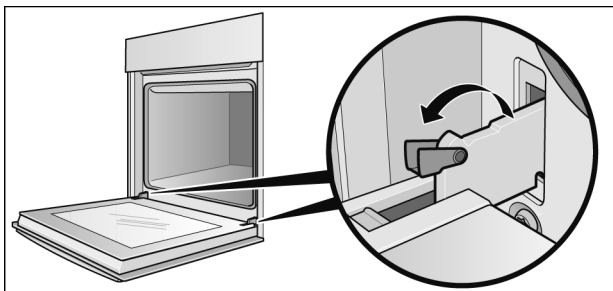

1. Open the appliance door fully.
2. Open the locking levers on the left and right-hand side fully.

The hinges are secured and cannot snap closed.

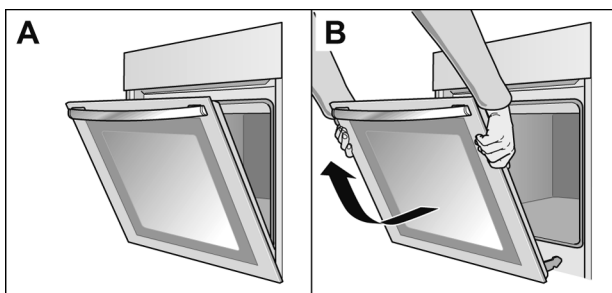

3. Close the appliance door only until resistance becomes noticeable (Fig. A).
4. With both hands, grip the door on the left and right-hand side, close the door a little more and pull it out (Fig. B).

Fitting the appliance door

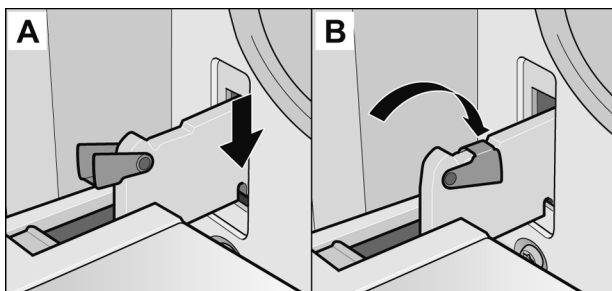

1. Insert the hinges in the left and right-hand holders (Fig. A).

The notch on both hinges must engage.

2. Open the appliance door fully.
3. Close the locking levers on the left and right-hand side fully (Fig. B).

The appliance door is secured and can no longer be removed.

4. Close the appliance door.

Cleaning the door panels

To facilitate cleaning, you can remove the inner door panels from the appliance door.



Risk of injury.

The components inside the appliance door may have sharp edges. Take care not to cut yourself. Wear protective gloves.

Caution.

The appliance must not be used again until the door panels and the appliance door have been correctly fitted.

Removing the door panel

1. Remove the appliance door and place on a soft, clean surface with the front side facing down (see section: Removing and fitting the appliance door).

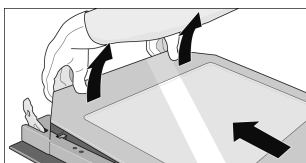

2. Grip the door panel next to the hinges and pull it out of the plug-in holders (not visible).
3. Lift the door panel slightly and remove it in the direction of the hinges.

Removing the intermediate panel

Before removing, make a note of the position in which the intermediate panel is fitted, so that you do not refit it the wrong way round later.

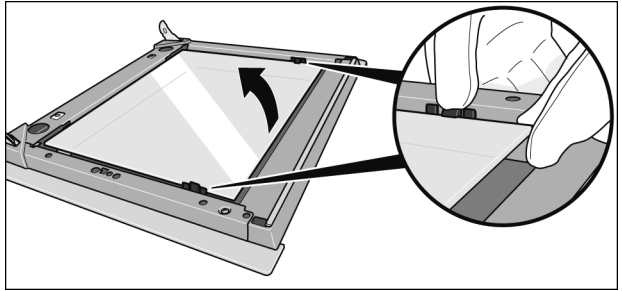

1. Press the left and right-hand holders outwards.
The intermediate panel disengages upwards.
2. Lift the intermediate panel slightly and take it out.

Cleaning

Clean the door panels with glass cleaner and a soft cloth.

Caution.

Do not use any sharp or abrasive medium or a glass scraper. The glass could become damaged.

Fitting the intermediate panel

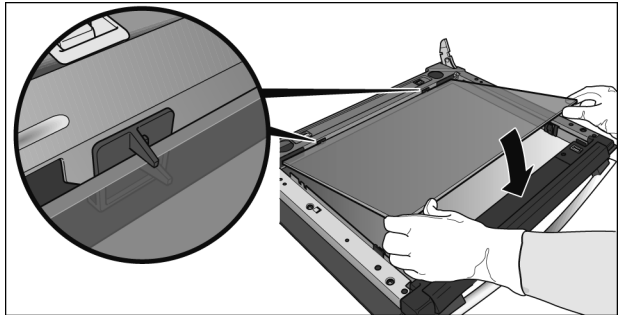

1. Insert the intermediate panel on the left and right into the supports.
2. Press the intermediate panel downwards into the holders.

Fitting the door panel

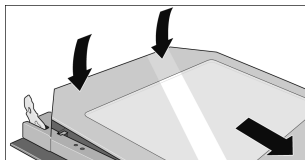

1. Insert the door panel on the left and right into the supports.
2. Press the door panel downwards into the plug-in holders.
3. Refit the appliance door.

Cleaning the cooking compartment ceiling

The grill element can be folded down to allow quick and easy cleaning of the cooking compartment ceiling.



Risk of burns from hot parts in the cooking compartment. Wait until the cooking compartment has cooled down.

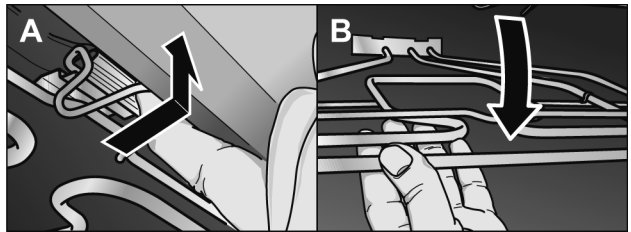

1. Pull the grill element retaining bracket towards the front and push it upwards until you hear it disengage (Fig. A).
2. Hold the grill element and fold it downwards (Fig. B).
3. Clean the cooking compartment ceiling.
4. Pull the retaining bracket towards the front and keep it pushed upwards.
5. Fold the grill element upwards, until it clicks into place.

Cleaning the hook-in racks

You can remove the hook-in racks for easier cleaning.



Risk of burns from hot parts in the cooking compartment. Wait until the cooking compartment has cooled down.

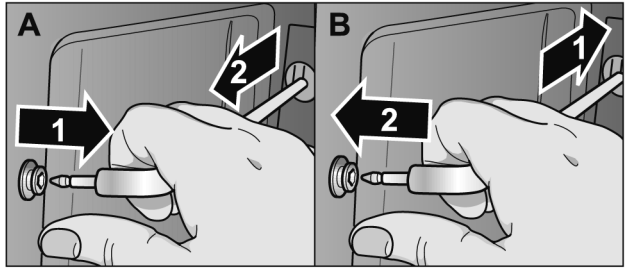

1. Pull out and detach the hook-in rack at the front (figure A).
2. Clean the hook-in rack with washing-up liquid and a sponge or brush.
3. After cleaning, refit the hook-in rack in the opposite sequence (figure B).

Cleaning the telescopic shelves

You can unhook the telescopic shelves for easier cleaning.



Risk of burns from hot parts in the cooking compartment. Wait until the cooking compartment has cooled down.

Removing the telescopic shelves

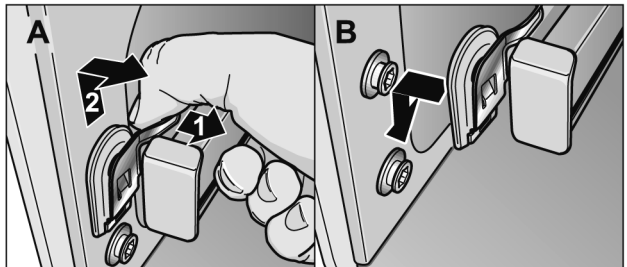

1. Pull and hold the flat spring (figure A).
2. Move the telescopic shelf upwards at the front and unhook it to the side.
3. Pull out the telescopic shelf at the back.

Cleaning the telescopic shelves

Clean the telescopic shelves with washing-up liquid and a sponge or brush.

Refitting the telescopic shelves

1. Insert the telescopic shelf at the back as far as the stop.
2. Insert the telescopic shelf at the front from the top and push it down until it engages (figure B).
3. Slide in the telescopic shelves as far as the stop and close the appliance door.

Faults and repairs



It is not always necessary to call the after-sales service. In some cases, you can take remedial action yourself. You will find some tips for troubleshooting in the following table.



Risk of electric shock.

- Work on the appliance electronics must only be carried out by an expert
- During work on the appliance electronics, the power supply to the appliance must be disconnected. Switch off the circuit breaker or take out the fuse in your household fuse box

Problem	Possible cause	Remedial action
Electrical operation is malfunctioning (e.g. indicator lamps do not light up)	Blown fuse	Check the fuses in the fuse box and replace if necessary
Liquid or thin dough runs to one side	Appliance not installed level	Check the appliance installation (see Installation instructions)
The appliance no longer functions, 0:00 flashes in the clock display	There was a power cut	Reset the clock (see section: Electronic clock)
0:00 flashes in the clock display, "rrr" appears in the temperature display	Power supply was interrupted while the appliance was in operation	Press the clock function button, Reset the clock (see section: Electronic clock)

Problem	Possible cause	Remedial action
It is not possible to operate the appliance,  and -5- appear in the temperature display	The appliance has been locked	Deactivate the lock (see section: Childproof lock)
It is not possible to operate the appliance,  and -5P appear in the temperature display	The appliance has been locked permanently	Deactivate the permanent lock (see section: Childproof lock)
The appliance does not heat up, the colon flashes in the clock display, 1500 appears in the temperature display, for example	A key combination was activated	Switch off the appliance, press and hold the info button for 3 seconds, then press and hold the clock function button for 4 seconds before pressing the info button again and holding it for a further 3 seconds
Electronically controlled functions are malfunctioning	Energy surges (e.g. lightning strike)	Reset the function concerned
When an operating mode is activated, H or h appears in the temperature display	The appliance has not cooled down fully	Wait until the appliance has cooled down, then switch on the operating mode again
The appliance has switched itself off automatically, 000 flashes in the temperature display	The appliance has switched off to protect itself from overheating	Turn the operating mode selector back to the  position
Smoke is generated during roasting or grilling	Fat is burning on the grill element	Continue grilling or roasting until the fat on the grill element is burnt away
	Wire rack or universal pan inserted incorrectly	Place the wire rack in the universal pan and insert them together at a low shelf height
High levels of condensation are generated in the cooking compartment	Normal occurrence (e.g. with cakes with very moist toppings or a large roasting joint)	Open the appliance door occasionally during operation
Enamelled accessories have light, matt stains	Normal occurrence caused by dripping meat or fruit juices	Not possible
Door panels are misted up	Normal occurrence caused by temperature differences	Heat the appliance up to 100 °C and then switch off again after 5 minutes

Changing the cooking compartment bulb

Replace faulty cooking compartment bulbs. Spare bulbs can be obtained from the after-sales service or specialist shops:
E14, 220 - 240 V, 40 W, heat resistant to 300 °C
Use these bulbs only.



Risk of electric shock.

Disconnect the appliance from the power supply. Switch off the circuit breaker or take out the fuse in the household fuse box.

1. Place a tea towel in the cold oven to prevent damage.

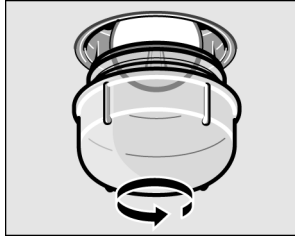

2. Turn the glass cover anticlockwise and remove it.
3. Replace the bulb with one of the same type.
4. Screw on the glass cover again.
5. Remove the tea towel and switch on the fuse.

Replacing the door seal

If the door seal is defective, it must be replaced. Replacement seals for your appliance can be obtained from the after-sales service.

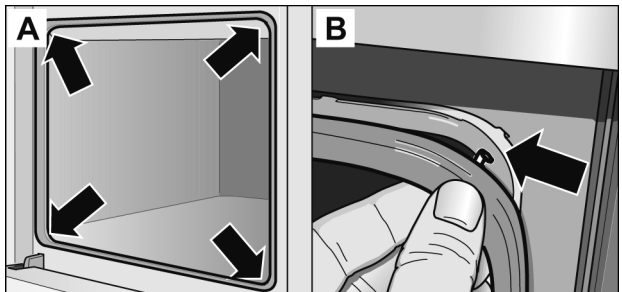

The door seal is attached in four places (figure A). To replace it, disconnect or attach the hooks at all four points (figure B).

Check to ensure in particular that the seal is seated correctly in the corners.

After-sales service

In the event of faults and repairs that you cannot solve yourself, please use our after-sales service.

You can find the addresses in the after-sales service directory.

Note:

You will be charged for calling the after-sales service regarding an operating fault.

E number and FD number





For after-sales service cases, please specify the E-number and FD number.

You can find these on the rating plate behind the appliance door on the left-hand bottom edge.

E-Nr.	FD
-------	----

Test dishes









Dishes tested in accordance with standard EN 60350. Please note the information in the tables about preheating. The table values do not include rapid heating.

Baking	Cookware	Setting	Level	Temperature in °C	Time in minutes
Shortbread					
■ 1 level	Baking tray***		3	140 - 150**	20 - 25
■ 1 level	Baking tray***		1	140 - 150**	20 - 30
■ 2 levels	2 baking trays***		1 + 3	140 - 150**	20 - 30
■ 3 levels	3 baking trays***		1 + 3 + 4	130 - 150**	35 - 45

* Preheat for 10 minutes

** Preheat oven

*** Only use original baking trays, order no. Z1342X0

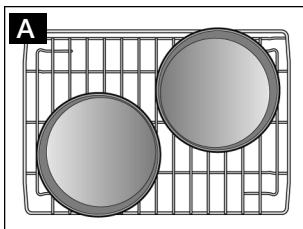

Baking	Cookware	Setting	Level	Temperature in °C	Time in minutes
Small cakes (20 pieces)					
■ 1 level	Baking tray***		3	160 - 170*	25 - 35
■ 1 level	Baking tray***		1	150 - 160*	25 - 35
■ 2 levels	2 baking trays***		1 + 3	150 - 160*	25 - 35
■ 3 levels	3 baking trays***		1 + 3 + 4	150 - 160*	25 - 35
Fatless sponge cake					
	Springform cake tin ø 26 cm		2	160 - 170**	25 - 35
			1	160 - 170**	25 - 35
Apple pie					
■ 1 level (see figure A)	2 x Springform cake tin ø 20 cm		1	170 - 180**	70 - 80
■ 2 levels (see figure B and C)	2 x Springform cake tin ø 20 cm		1 + 3	170 - 180**	70 - 80
Apple pie	2 x Springform cake tin ø 20 cm		1	170 - 180**	70 - 80
* Preheat for 10 minutes					
** Preheat oven					
*** Only use original baking trays, order no. Z1342X0					

If you are baking apple pie with  CircoTherm®, always place the two springform cake tins diagonally from each other on the flat wire rack (Figure A).

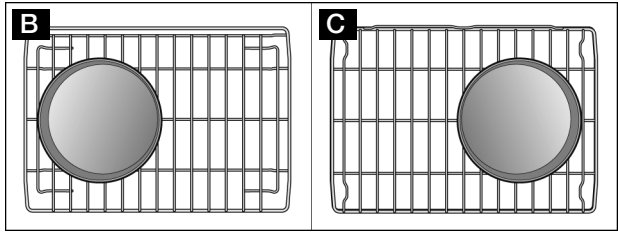

If you are baking apple pie on two levels, place the lower baking tin to the left (Figure B) and the upper baking tin to the right (Figure C) on their respective wire racks.



Grilling	Cookware	Setting	Level	Temperature in °C	Time in minutes
White bread	universal pan + flat wire shelf		4	<i>int</i> *	0,5 - 2
Beefsteaks	universal pan + flat wire shelf		4	<i>int</i>	20 - 25**

* Preheat for 10 minutes

** Turn after $\frac{2}{3}$ of the time